

**SORTER STAPLER**  
**(Machine Code: A831)**

# 1. OVERALL MAHCINE INFORMATION

## 1.1 SPECIFICATIONS

Configuration: Console  
 Number of Bins: 20 + Proof Tray  
 Paper for Proof Tray:  
     Size: Maximum: 13" x 19"  
           Minimum: A6 lengthwise, 5 1/2" x 8 1/2"  
     Weight: 64 ~ 157 g/m<sup>2</sup>, 17 ~ 42 lb.  
     Capacity: 250 sheets (80 g/m<sup>2</sup>, 20 lb.)  
 Paper for Bins: See the table below.

	Sort	Stack	Staple
Maximum paper size	13" x 19"	13" x 19"	13" x 19"
Minimum paper size	Sideways: A5, 5 1/2" x 8 1/2" Lengthwise: A5, 5 1/2" x 8 1/2"	Sideways: A5, 5 1/2" x 8 1/2" Lengthwise: A6, 8 1/2" x 5 1/2"	B5, 8 1/2" x 11"
Maximum paper weight	250 g/m <sup>2</sup> , 66 lb.	250 g/m <sup>2</sup> , 66 lb.	200 g/m <sup>2</sup> , 53 lb.
Minimum paper weight	64 g/m <sup>2</sup> , 17 lb.	64 g/m <sup>2</sup> , 17 lb.	64 g/m <sup>2</sup> , 17 lb.
Maximum capacity	All sizes: 50 sheets/bin 2 sided copies: 40 sheets/bin	All sizes: 50 sheets/bin 2 sided copies: 40 sheets/bin	All sizes 50 sheets/bin 2 sided copies: 40 sheets/bin

Staple Position:

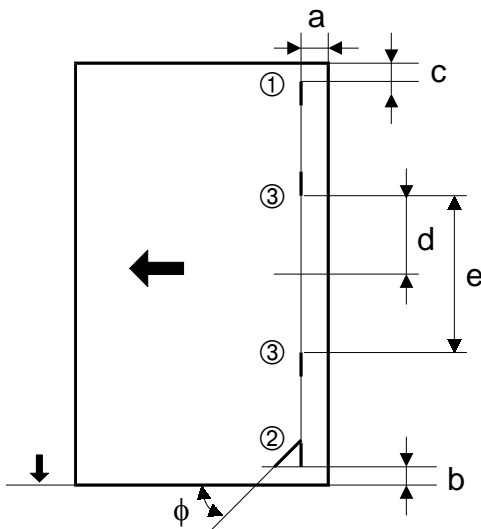

- Staple mode 1 ..... ①
- Staple mode 2 ..... ②
- Staple mode 3 ..... ③

- a = 6 ± 3 mm
- b = 6 ± 3 mm
- c = 6 ± 3 mm
- d = 66 ± 3 mm
- e = 132 ± 2 mm
- φ = 45 ± 5°

A831V500.WMF



## SPECIFICATIONS

30 March, 1999

Staple Replenishment:	Cartridge refill (5,000 pieces/cartridge)
Power Source:	DC24 V (from copier)
Power Consumption:	Average: less than 60 W
Dimensions (W x D x H):	600 x 615 x 980
Weight:	Approximately 65 kg

## 1.2 COMPONENT LAYOUT

### 1.2.1 MECHANICAL COMPONENT LAYOUT

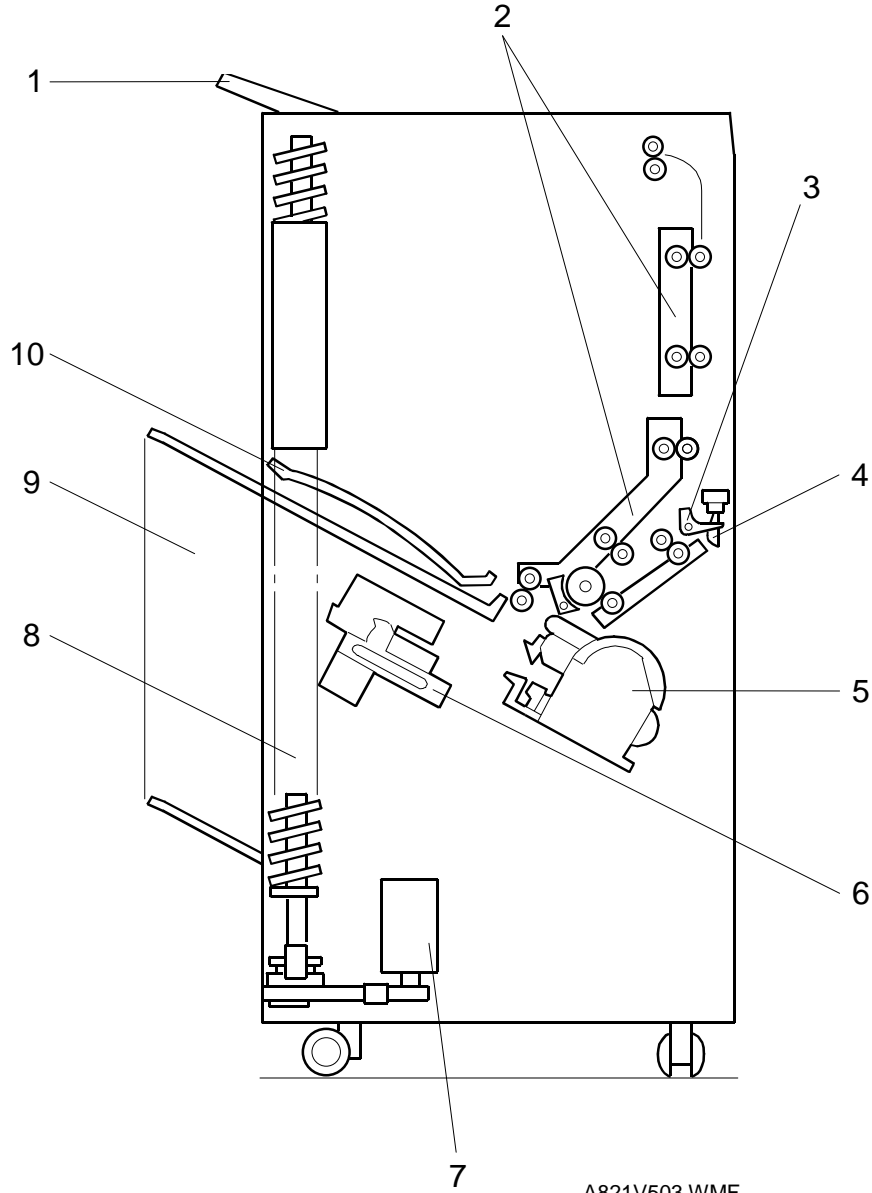

A821V503.WMF

- 1. Proof tray
- 2. Reverse unit
- 3. Turn gate
- 4. Entrance sensor
- 5. Staple unit
- 6. Grip assembly
- 7. Bin drive motor
- 8. Helical wheels
- 9. Bins
- 10. Upper guide plate

Peripherals

**1.2.2 DRIVE LAYOUT**

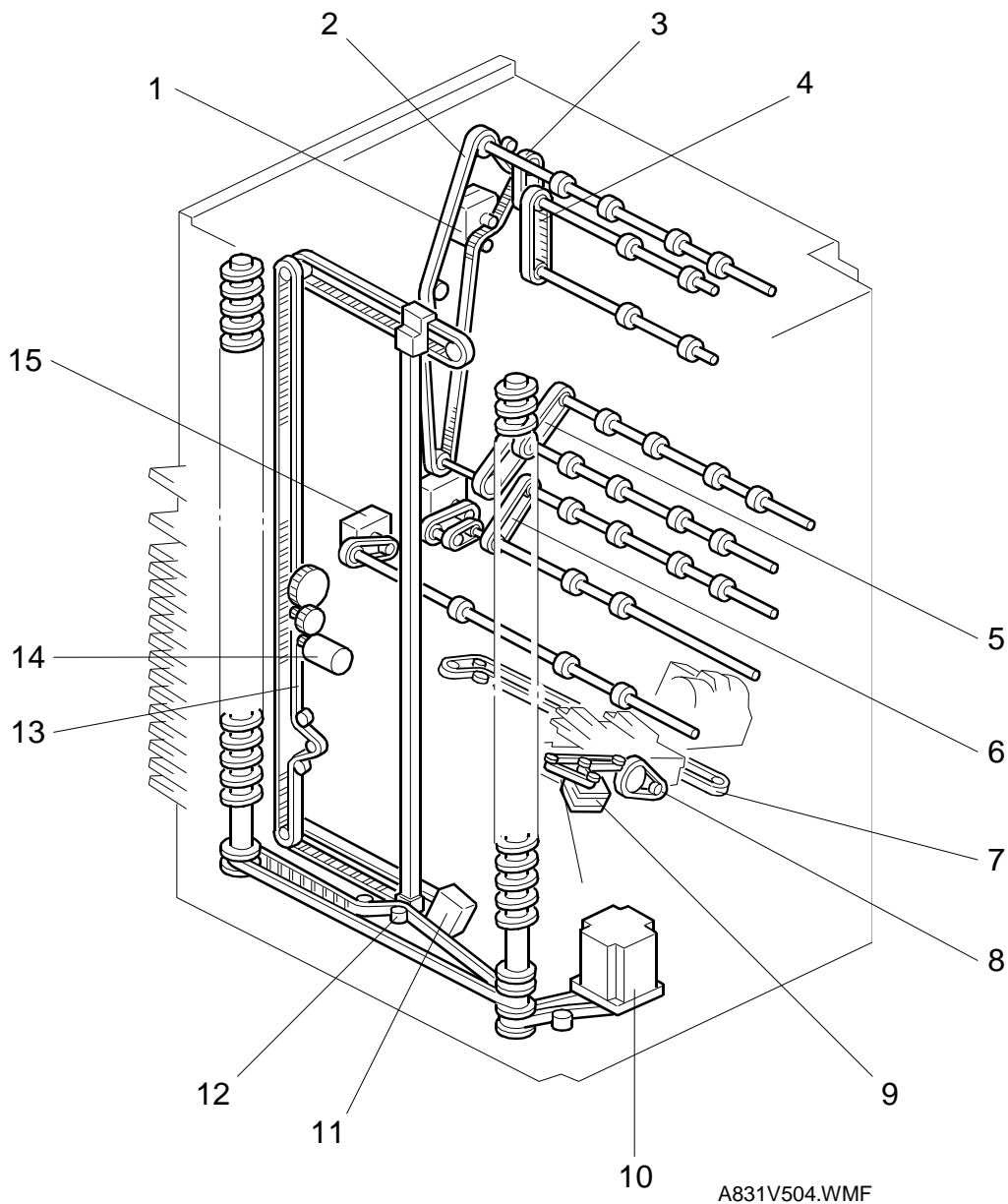

A831V504.WMF

- |                           |                               |
|---------------------------|-------------------------------|
| 1. Main motor             | 9. Gripper drive motor        |
| 2. Main drive belt        | 10. Bin drive motor           |
| 3. Drive belt 1           | 11. Jogger motor              |
| 4. Drive belt 2           | 12. Wheel drive belts         |
| 5. Sort timing belt 1     | 13. Bin rear belt             |
| 6. Sort timing belt 2     | 14. Bin rear belt drive motor |
| 7. Staple unit drive belt | 15. Sorter exit motor         |
| 8. Gripper motor          |                               |

## 2. DETAILED DESCRIPTION

### 2.1 BASIC OPERATION

#### 2.1.1 NORMAL (PROOF MODE) AND SORT/STACK MODE

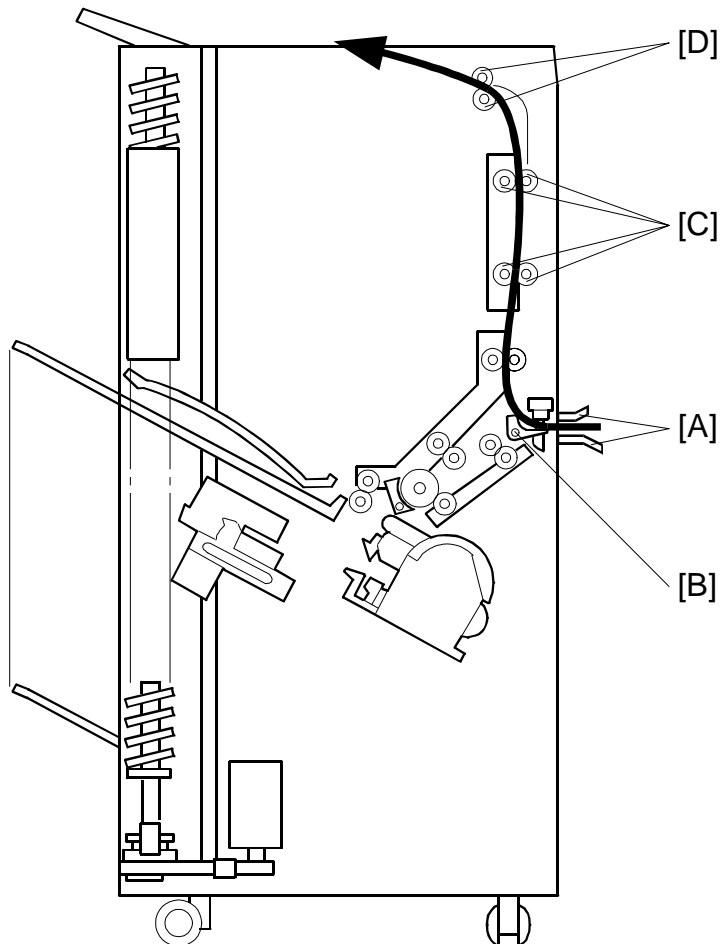

A831D151.WMF

Copies exiting the copier pass through the entrance guide plates [A] to the turn gate section. The turn gate [B] will send copies either to the proof tray or to the bins, depending on the mode.

#### ***Normal (Proof) Mode (From the Turn Gate Section to the Proof Tray)***

The turn gate solenoid energizes to turn the turn gate clockwise after pressing the Start key. The main motor turns counter-clockwise to rotate the vertical transport rollers [C] and proof exit roller [D]. The turn gate directs copies through the proof transport section to the proof tray.

**Sort Mode (From the Turn Gate Section to the Bins)**

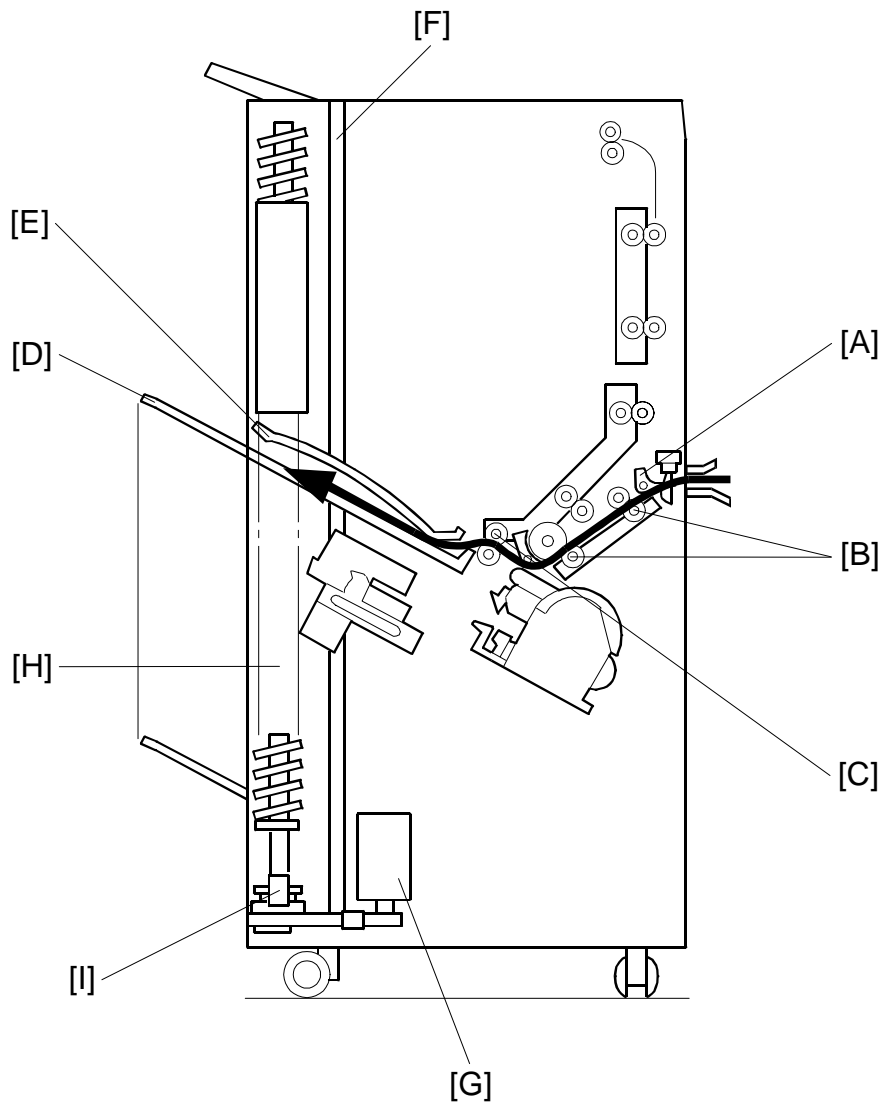

A831D152.WMF

In this mode, the turn gate solenoid remains off to maintain the turn gate [A] in the upper position. The main motor turns clockwise to rotate the sorter transport rollers [B] and the exit motor rotates the exit rollers [C].

The turn gate directs copies to the sorter bins through the sorter transport section, delivering the first copy between the top bin [D] and the upper guide plate [E]. The jogger plate [F] then jogs to square the copies each time. Before the next copy reaches the sorter exit roller, the bin drive motor [G] rotates and advances the bin one step (the helical wheels [H] rotate once). When the cut out of the actuator reaches below the wheel sensor [I], the bin drive motor turns off. The bin advances with each delivered copy.

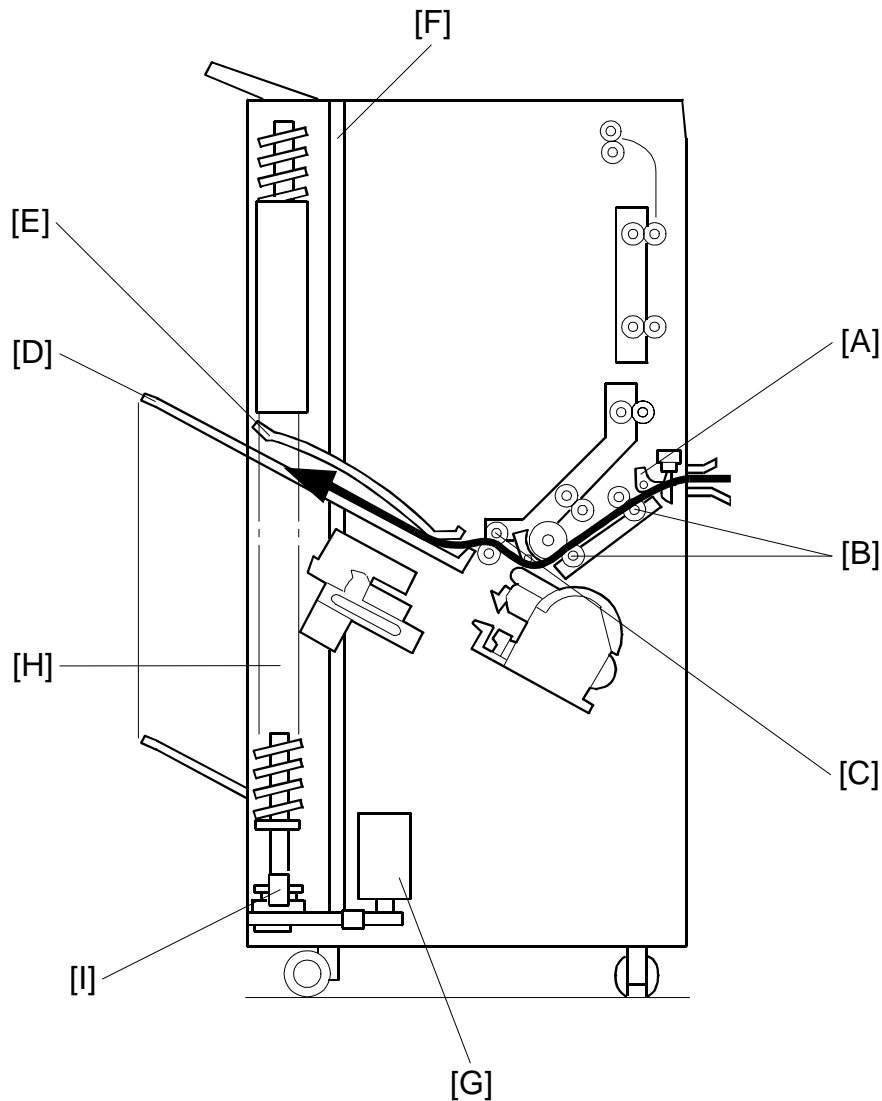
**Stack Mode (From the Turn Gate Section to the Bins)**

A831D152.WMF

As with sort mode, the turn gate solenoid stays off and the turn gate [A] stays up after pressing the start key. The main motor turns clockwise to rotate the sorter transport rollers [B] and the exit motor rotates the exit rollers [C].

The turn gate directs copies to the sorter bins through the sorter transport section, delivering the copies between the top bin [D] and the upper guide plate [E]. The jogger plate [F] then jogs back and forth to square the copies each time. All copies from the copy run then feed into the first bin. When the final copy is delivered, the wheel drive motor [G] turns and advances the bin one step (the helical wheels [H] rotate once). When the cut out of the actuator reaches below the wheel sensor [I], the bin drive motor turns off.



**Reverse Mode (From the Turn Gate Section to the Bins)**

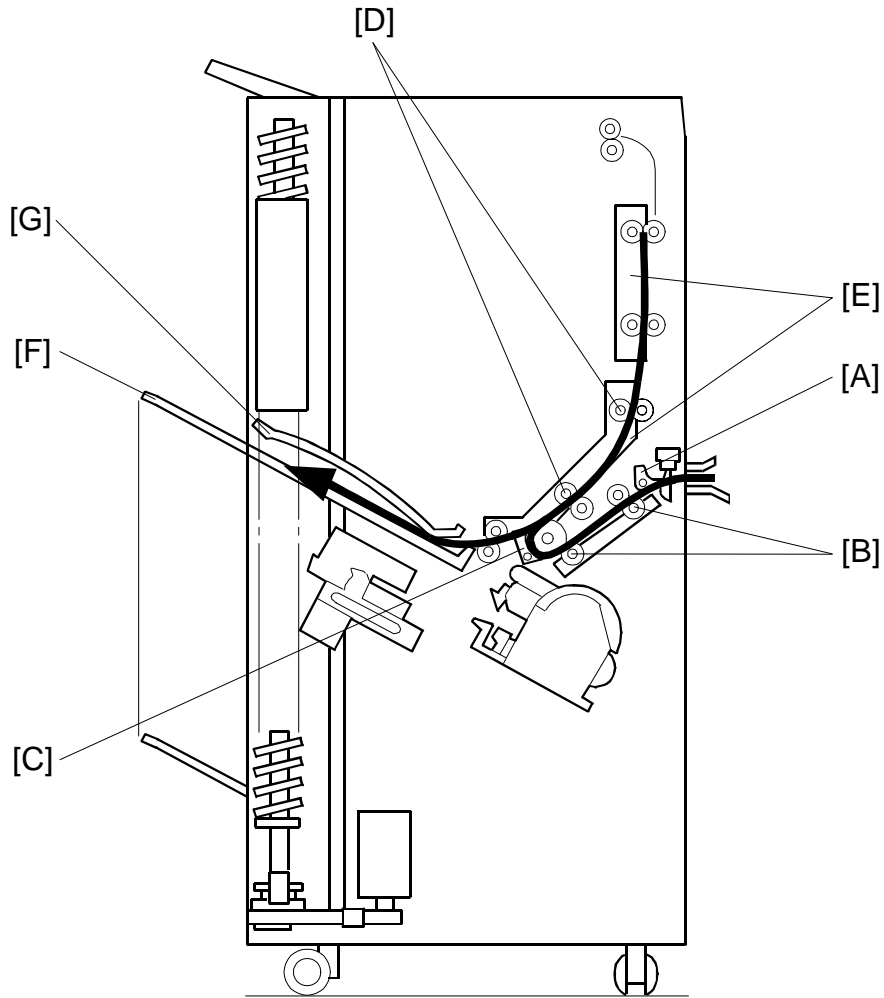

A831D152.WMF

As with reverse mode, the turn gate [A] stays up after pressing the start key. The main motor turns clockwise to rotate the sorter transport rollers [B]. Then reverse solenoid energizes to the reverse gate [C] counter-clockwise after pressing the start key. The reverse motor rotates the reverse rollers [D] to transport the paper into the reverse unit [E]. Then the reverse gate is released. Main motor and reverse motor rotates counter-clockwise to deliver the copies between the top bin [F] and the upper guide plate [G].

### 2.1.2 STAPLE MODE

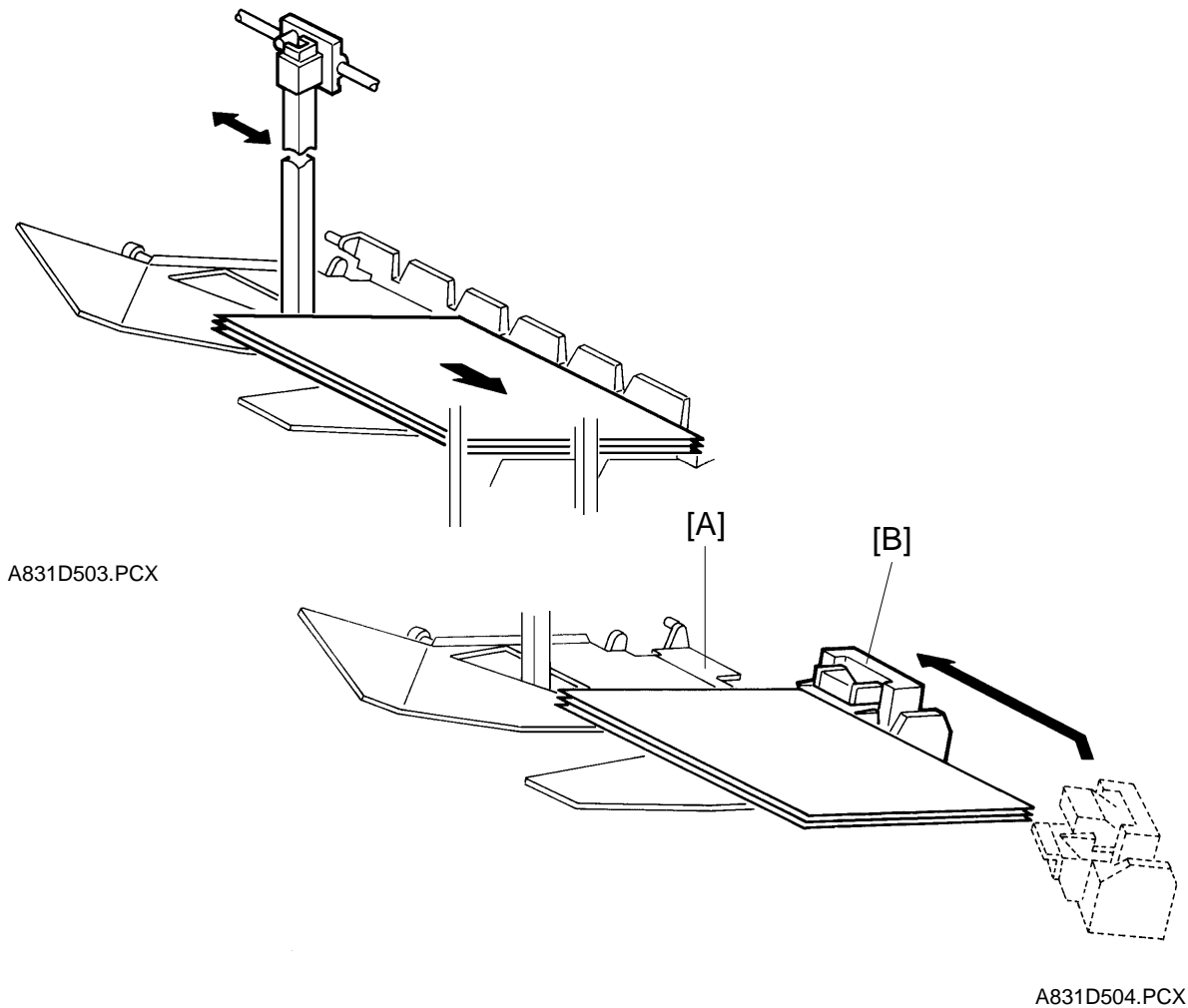

After jogging the final set of copies, the staple unit staples the stacked copies as follows: The grip arms move inside the front side plate and catch the paper. The rear bin plate [A] is turned so it is flat with the sorter bin. The grip assembly brings the copies down underneath the stapler [B]. The staple unit changes the position (the position varies depending on the copy size and staple mode) and the stapler staples the copies.

Peripherals

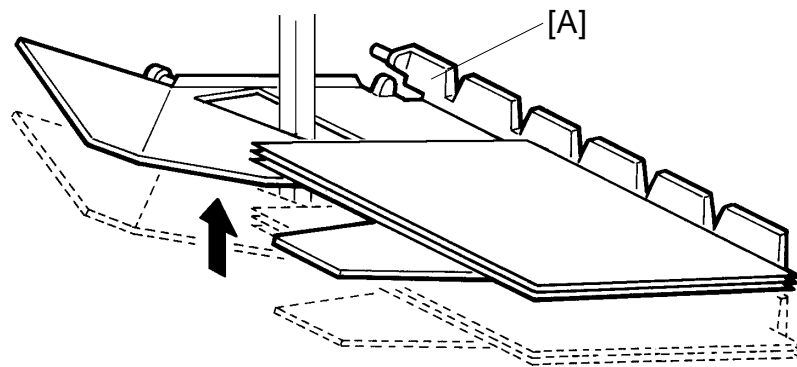

A831D505.PCX

The grip assembly brings the stapled copies back to the bin and the bin rear plate [A] returns to the original position.

The grip assembly releases the copies and return to outside the front side plate so as not to disturb the bin movement.

The bin advances one step.

After stapling the final set of copies, the staple unit returns to the home position.

There are two staple modes:

1) Automatic stapling:

In ADF mode, when the staple mode is selected before pressing the start key, copies will be delivered to each bin and stapled automatically.

2) Manual stapling:

In sort mode, after sorting the copies in the bins, the stapling mechanism will staple them after the user presses the manual staple key and selects the staple position. In stack mode, manual stapling is impossible.

## 2.2 TURN GATE SECTION

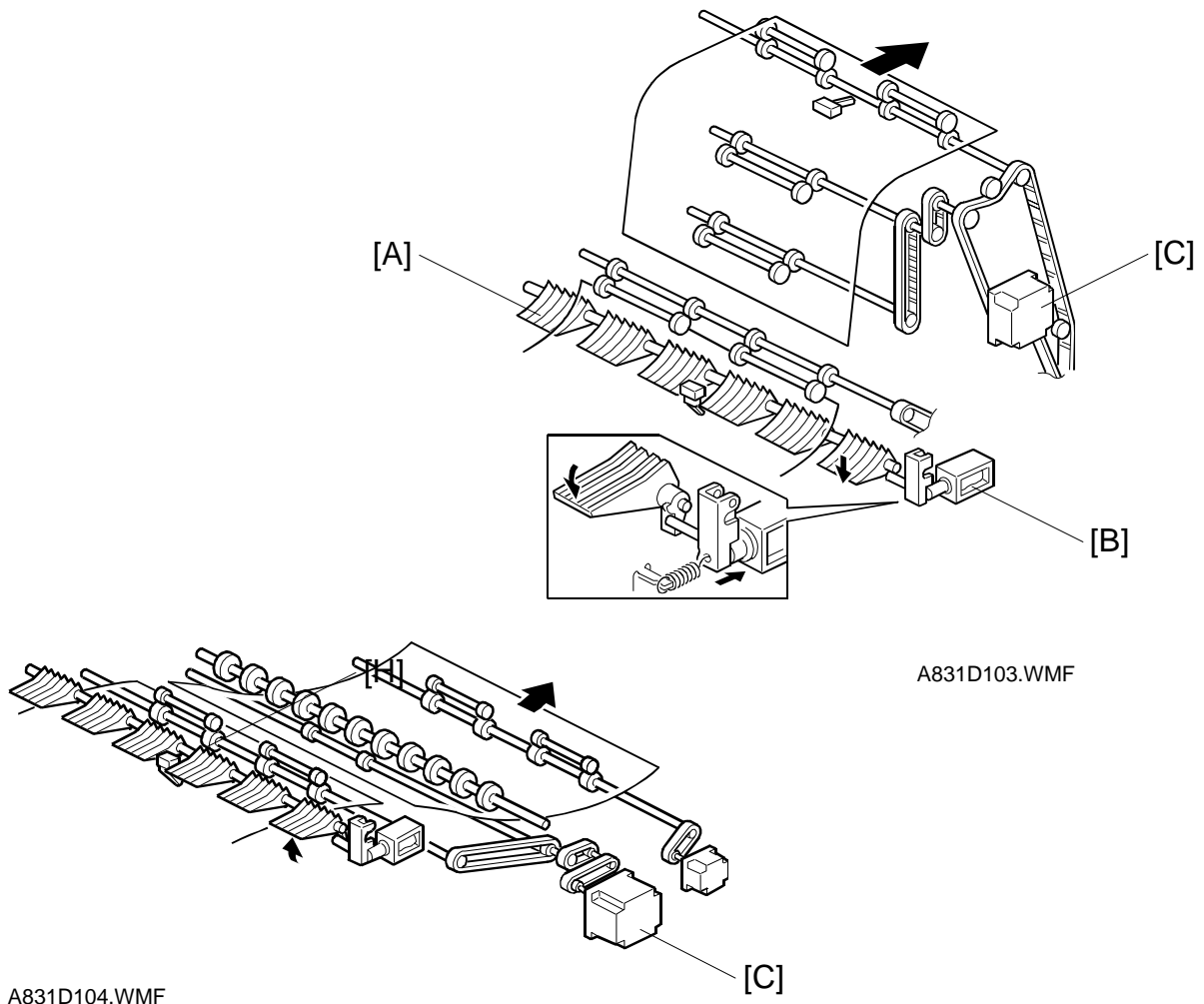

A831D104.WMF

The turn gate [A] sends copies to the proof tray or the sorter bins depending on the mode. In proof mode, the turn gate solenoid [B] turns on and the main motor [C] turns clockwise after pressing the start key.

The turn gate [A] directs copies upward through the proof transport section to the proof tray.

In the sort, stack and staple modes, the turn gate solenoid stays off to direct copies to the sorter transport section. After the user presses the start key, the main motor [C] turns counter-clockwise.

### 2.3 BIN DRIVE MECHANISM

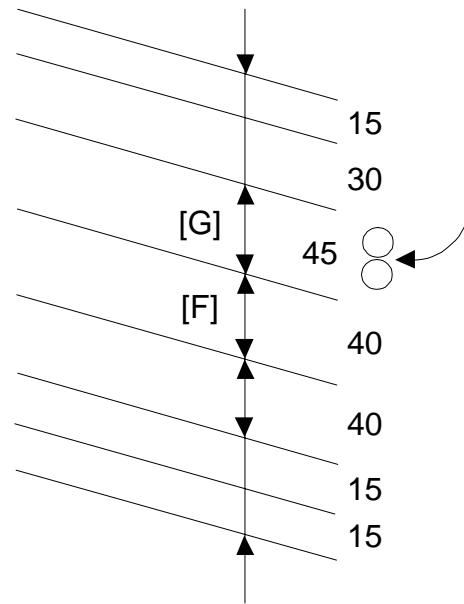
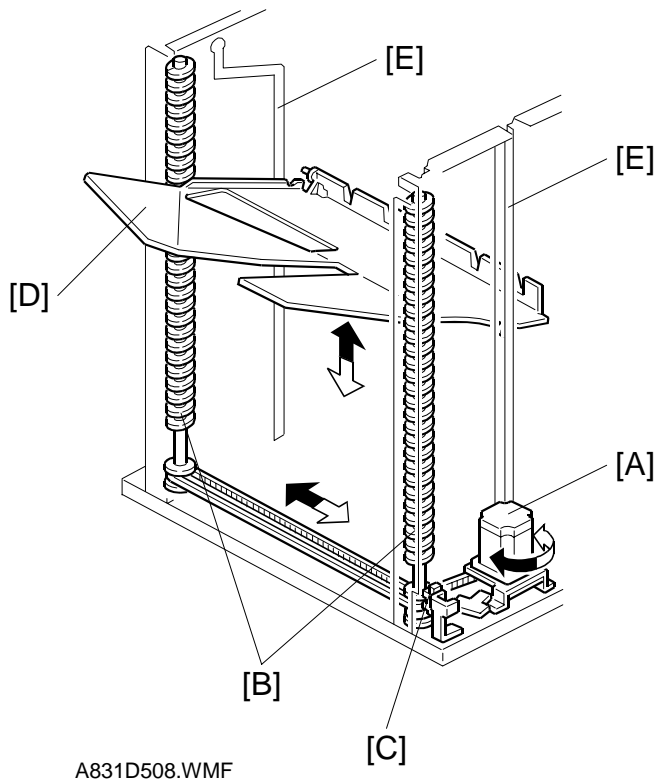

The bin drive mechanism moves the bins up and down to receive copies. The main components in this mechanism are the bin drive motor [A], the two helical wheels [B], the wheel sensor [C], and the bins [D] themselves. There are four pins on each bin. Two of them fit in the slot on the helical wheels. Other two fit into the slots [E] of the side frames. The pins slide up and down in these slots.

Two timing belts transmit the drive from the bin drive motor to the two helical wheels. When it rotates clockwise, the bins lift (black arrow) and when it rotates counter-clockwise, the bins lower (white arrow). There is a wheel sensor actuator on the front helical wheel; the actuator has a slot, which detects when the helical wheel has rotated 360 degrees.

When the bins advance, the helical wheels rotate once (360 degrees) for each step.

The spiral pitch on the helical wheel is greater when bins are at the staple and paper exit area than elsewhere. Consequently, the amount of bin shift is greater when bins are at the staple and paper exit area. This leaves enough space to staple [F] and stack paper [G] and reduces the total machine height.

## 2.4 BIN HOME POSITION

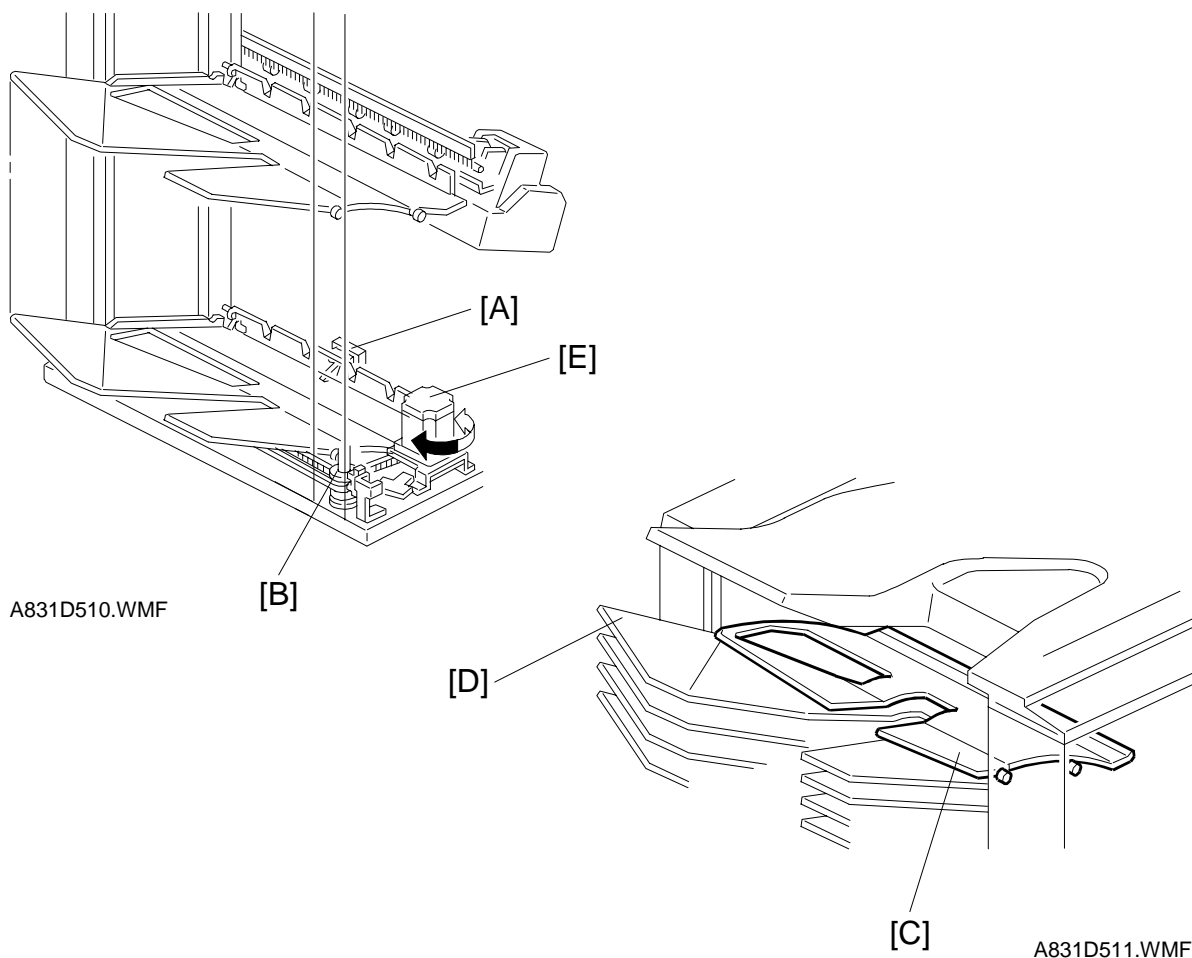

The bin HP sensor [A] and the wheel sensor [B] ensure that the sorter exit roller is between the upper guide plate [C] and the 1st bin [D] when all the bins are in their home position.

After turning on the main switch, the bin lift motor [E] lowers the bins (turns counter-clockwise) until the bottom bin actuates the bin HP sensor. Then, the bin lift motor raises the bins (turns clockwise) until the wheel sensor activates. Consequently, the bins are in the home position.

## 2.5 JOGGER SECTION

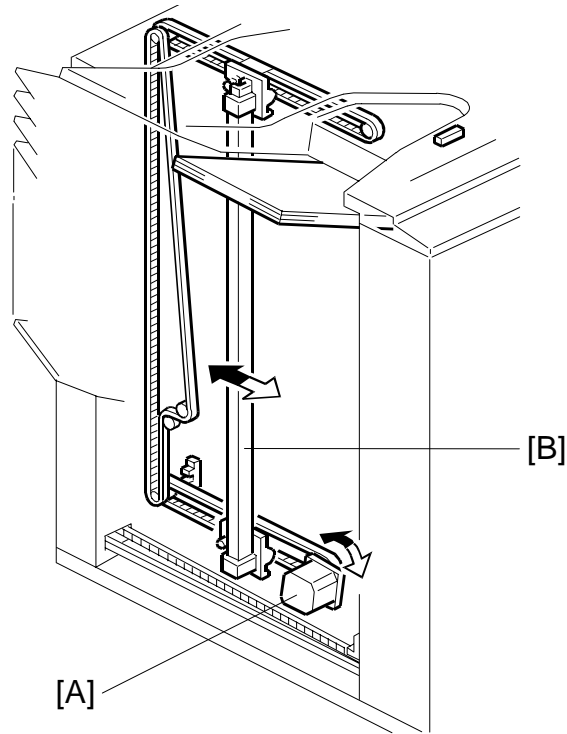

A831D512.WMF

After pressing the start key in the sort, staple and stack modes, the copier sends the paper size information to the sorter/stapler. In accordance with this data, the jogger motor [A] drives the jogger plate [B] from the jogger HP to a width 10 mm wider than the selected paper. 300 ms after the trailing edge of the copy passes underneath the jam sensor, the jogger motor rotates forward and in reverse. This makes the jogger plate push all the copies against the front side plate to square the sheets. When the jogger plate pushes the paper, the plate shifts to a position 5 mm wider than the paper size when the bins lift. It shifts to a position 1 mm narrower than the paper size when the bins lowers.

## 2.6 BIN REAR PLATE DRIVE SECTION

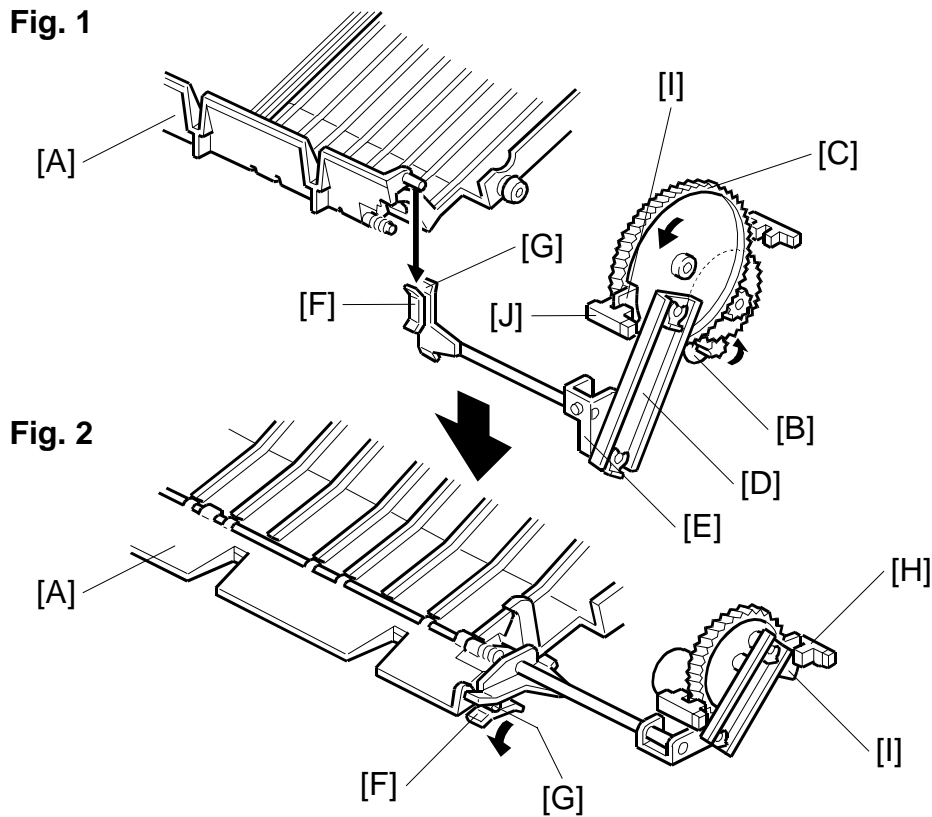

A831D515.WMF

The bin rear plates [A] stand up as shown (Fig. 1). They are lowered only during stapling as shown (Fig. 2).

In staple mode, when the jogger plate has jogged all copies, the bin rear plate drive motor [B] rotates a gear [C]. The gear [C] drives the piston rod [D], pushing the lever [E] down.

The holder [F] engaging the pin [G] on the bin rear plate lowers in accordance with the lever [E] position. Thus, the bin rear plate becomes flat so as not to interfere with the copies brought to the staple position by the grip assembly.

During stapling, the actuator [I] interrupts the rear plate open sensor [H] (Fig. 2) for the bin.

When the bin rear plates are in their home position, the actuator [I] interrupts their HP sensor [J] (Fig. 1).

Under this condition, a pin [G] enters the holder [F] or passes through it.

After stapling is complete and the stapled paper returns to the bin, the gear [C] rotates 180 degrees and the bin rear plate returns to its home position.



## **2.7 GRIP ASSEMBLY**

The grip assembly catches the jogged copies and moves them to the staple unit. After stapling, the grip assembly catches the copies again and moves them back. The grip assembly consists of grip arms, and the grip and grip shift motors. The grip arms catch the paper. The grip motor moves the grip arms inside and outside, and enables the grip arms to catch the paper. The grip shift motor causes the grip arms to carry the paper to the staple unit.

### 2.7.1 GRIP MOTOR

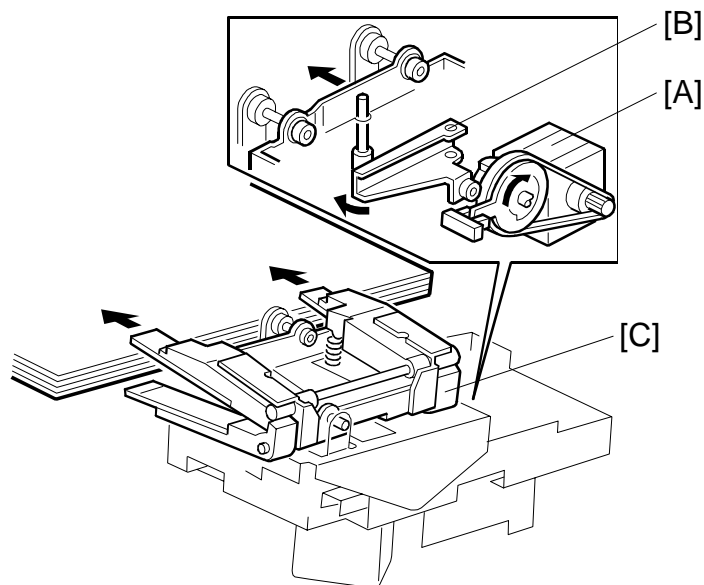

A831D516.WMF

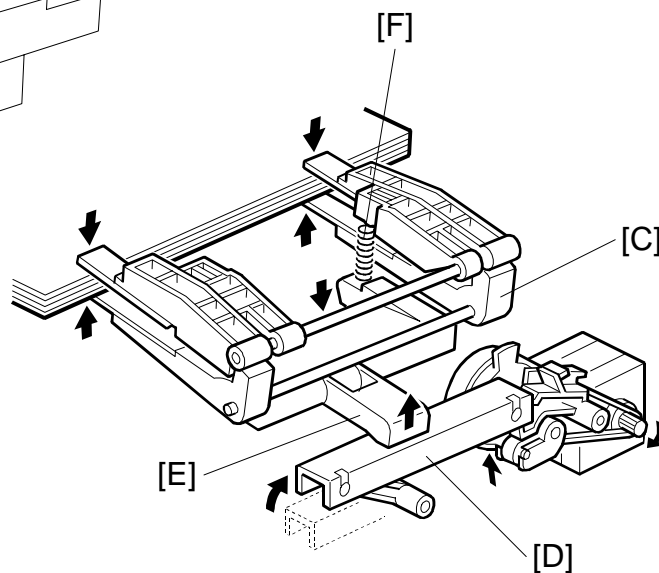

A831D517.WMF

When the grip motor [A] rotates several times, the lever [B] moves inside and pushes the grip arms [C]. After the grip motor rotates some more, the bracket [D] moves upward and pushes the pressure arm [E]. When the pressure arm move upward, the grip springs [F] attract the upper grip arms, then the grip arms catch the paper.



## 2.7.2 GRIP SHIFT MOTOR

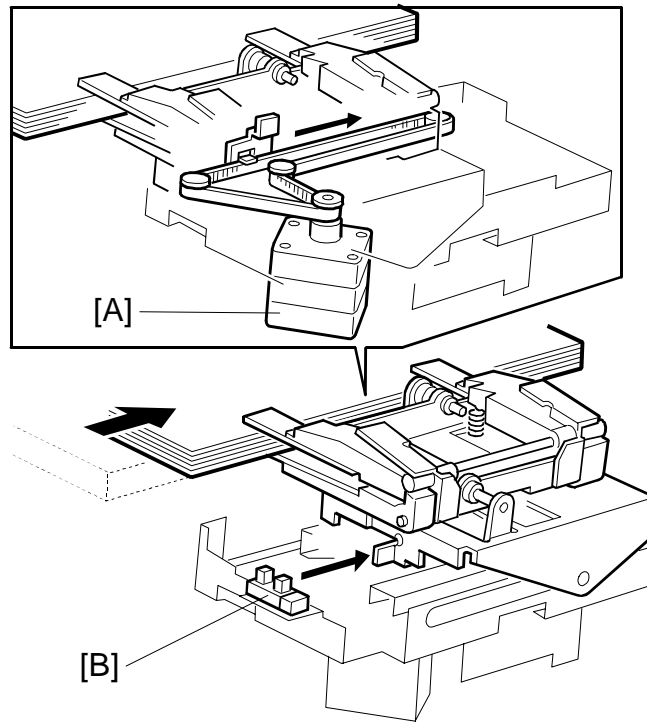

A831D518.WMF

The grip shift motor [A], a stepper motor, enables the grip arms to carry the paper to the staple unit and after stapling make it carry them back. The grip shift motor HP sensor [B] is actuated while the gripper is in the home (grip) position. The sorter/stapler main control board sends the appropriate pulses to the grip shift motor to determine the grip and staple positions. Vertical staple positions are adjusted by changing the DIP SW 2 on the main control board of sorter stapler.

## 2.8 STAPLE UNIT

### 2.8.1 STAPLE UNIT DRIVE MECHANISM

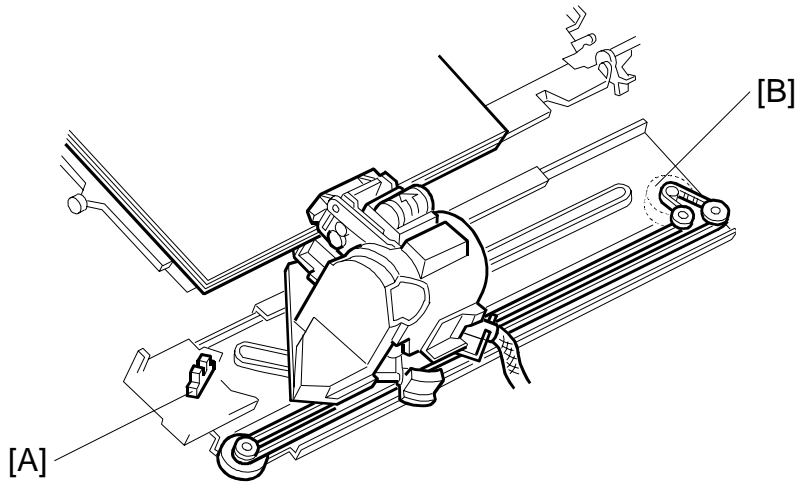

A831D519.WMF

The staple unit moves from the home position (top slant position) to the rear side of the machine in order to change the staple position. The staple HP sensor [A] activates when the staple unit is in the home position. In Top Slant mode, the stapler is only at the home position. In “Top” (or “Bottom”) single staple mode, the staple unit moves to the front (or rear) single staple position and stays there until stapling is complete. It then returns to the home position. In “2 Staples” mode or “Bottom” single staple mode; the staple positions differ according to the paper size. The staple unit drive motor [B] is a stepper motor, and the number of steps from the home position determine the staple position. In “2 Staples” mode, the staple unit goes back and forth to staple the two positions. Horizontal staple positions are adjusted by changing the DIP SW 2 on the main control board of sorter stapler.

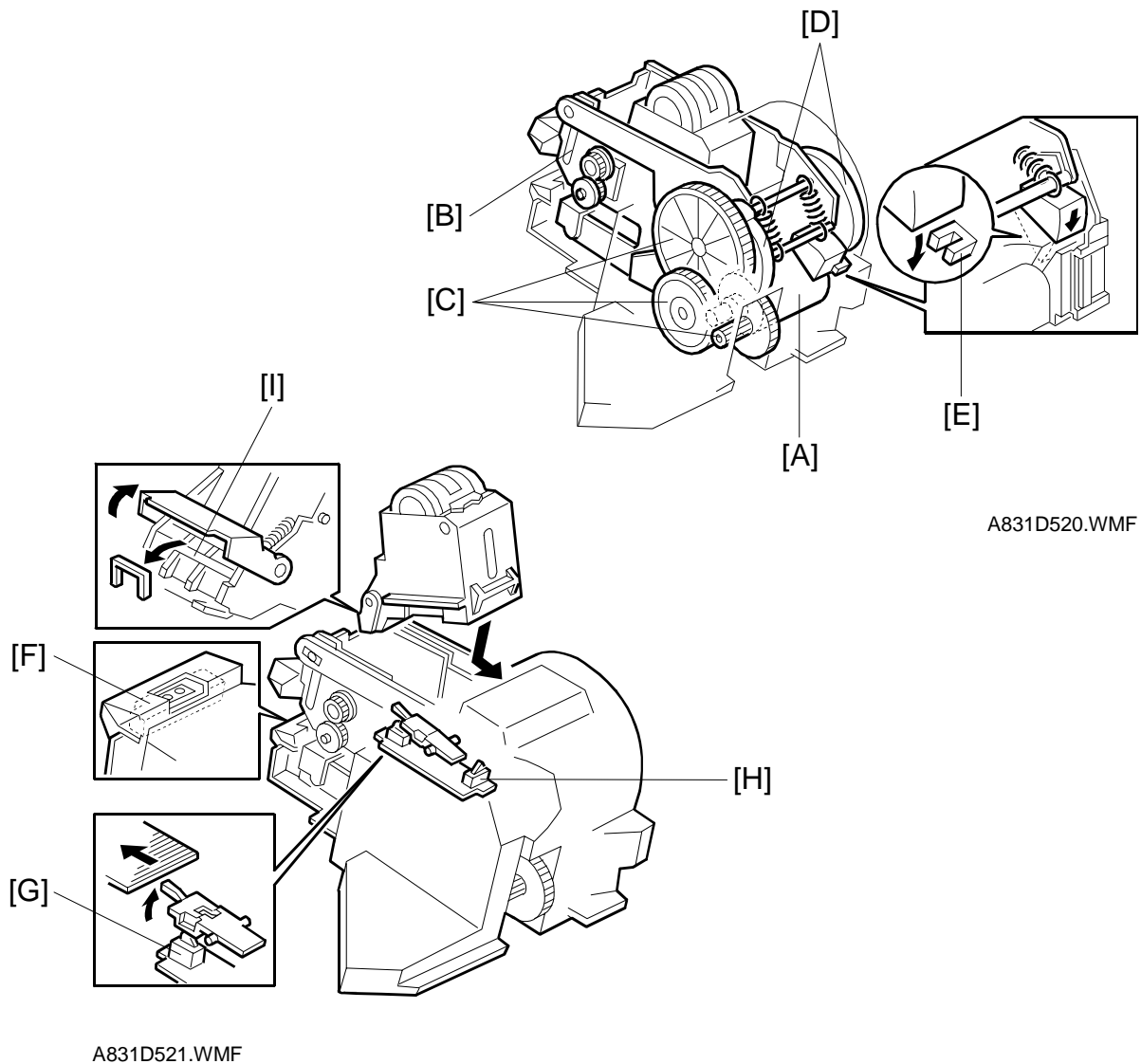
**2.8.2 STAPLER**

The stapler motor [A] drives the staple sheet drive belt.

The staple sheets go under the hammer [B].

The stapler motor drives the staple hammer via gears [C], two eccentric cams [D].

When the grip brings the aligned copies to the staple position, the stapler motor starts rotating. When the cams complete one rotation, the staple HP sensor [E] is de-actuated. The stapler motor then stops.

When the paper sensor [F] in the grip assembly does not detect that the copies are under the hammer, the stapler motor does not rotate.

There are two sensors in the staple unit. One is the staple end sensor [G], which detects staple end conditions. The other is the cartridge set sensor [H], which detects when the staple cartridge is not installed.

The staple cartridge has a clinch area [I], a deposit for jammed staples. Operators can remove the jammed staples from the cartridge.

### ***Staple Prohibit Conditions***

1. Under the following conditions, staple mode is disabled after pressing the staple key on the operation panel:

If paper is in the bin before turning on the main switch.  
If the selected paper size does not match stapling specifications.  
If the paper comes from the by-pass feed table.

2. Under the following conditions, staple mode is canceled:

If paper is manually loaded into a bin after selecting staple mode.  
If only one sheet is delivered to the bin.  
If the stack, slip-sheet or interrupt modes are selected.

3. Under the following conditions, manual stapling mode in sort mode is prohibited:

If paper is manually loaded into a bin after selecting sort mode.  
If the paper size in the bin does not match stapling specifications.  
If only one sheet is delivered to the bin.  
The delivery of a smaller width paper to the bin later in "Mixed Sizes" mode.  
If copies already stapled, remain in the bin.

### 2.8.3 STAPLE UNIT PULLED-OUT MECHANISM

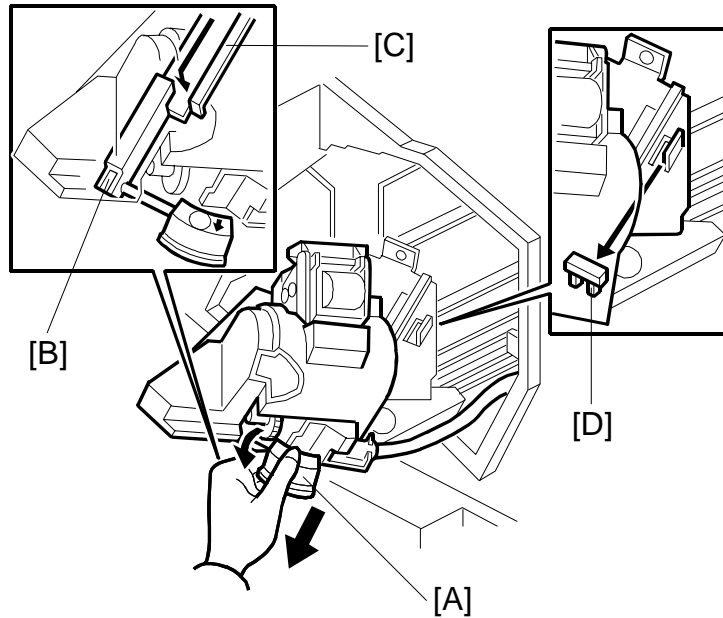

A831D524.WMF

For easy staple cartridge replenishment, the staple unit can be pulled-out from the front. Pulling out the R3 release grip [A] releases the stopper and enables the staple unit to be removed (staple unit pulled-out position). In this position, the stopper arm [B] locks the staple unit by dropping the arm to the edge of bracket [C]. When the staple unit is not in completely (the staple unit is between the staple unit HP and the staple unit pulled-out positions [D]), the LCD displays a message advising the user to set the staple unit in the home position.

## 3. REPLACEMENTS AND ADJUSTMENTS

### 3.1 EXTERIOR COVER REMOVAL

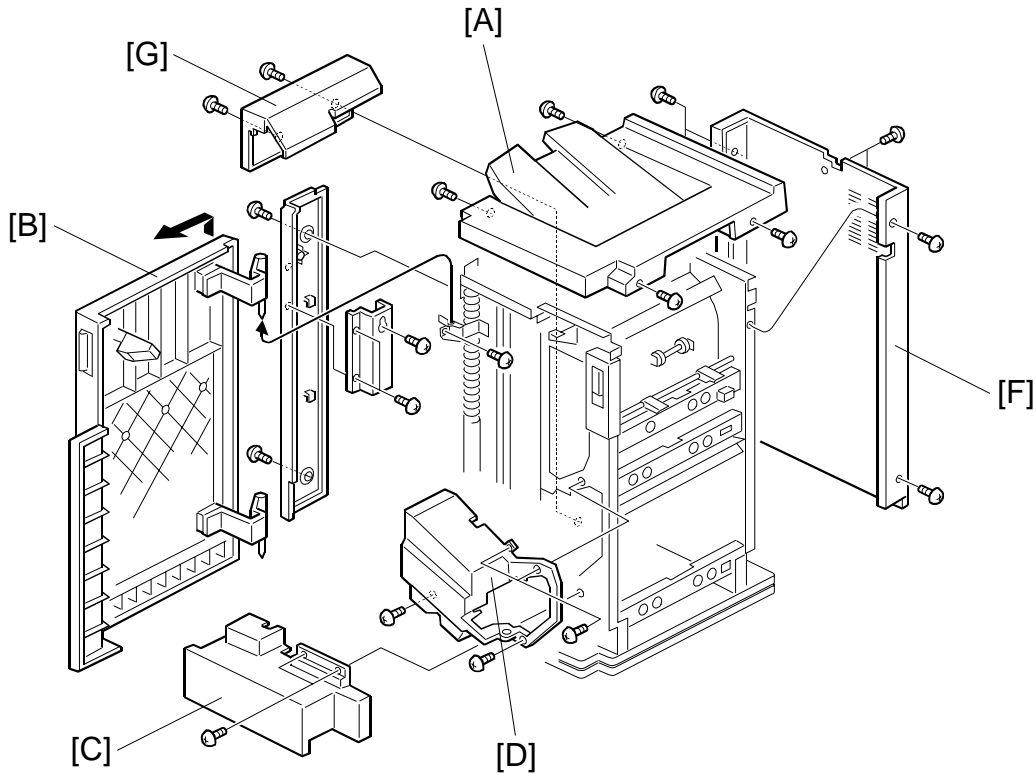

A831R101.WMF

1. Remove the proof tray [A] (2 screws).
2. Open the front door [B] and push away the staple unit.
3. Remove the lower cover [C].
4. Remove the front inner cover [D] (3 screws).
5. Remove the left front cover [E] (2 screws).
6. Lift up the front door and remove it.
7. Remove the rear cover [F] (4 screws).
8. Remove the left upper cover [G] (2 screws).



### 3.2 STAPLER REMOVAL AND REINSTALLATION

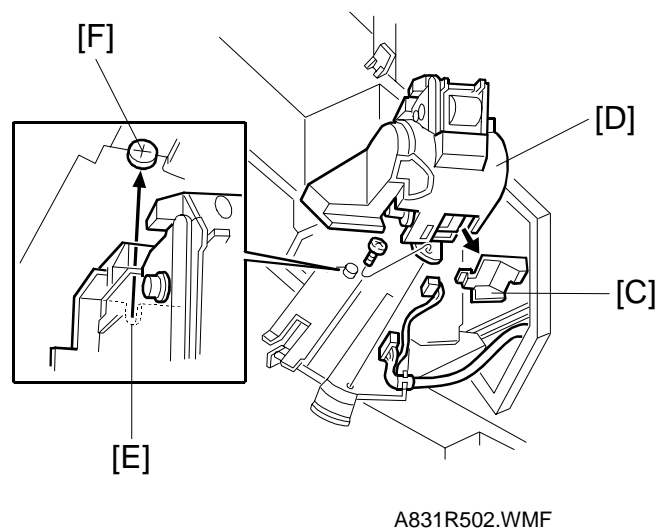
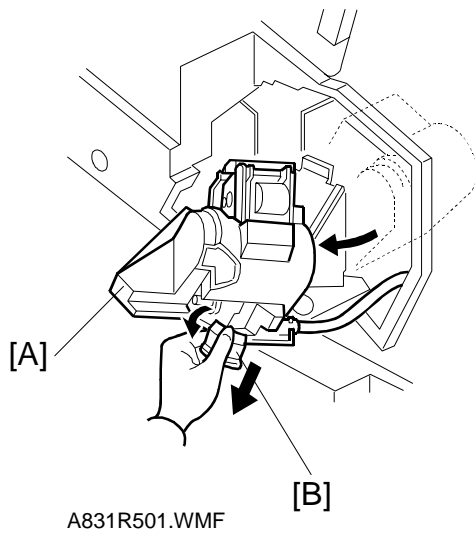

1. Return the stapler unit [A] to the home position by pulling out the stapler unit.
2. Pull out the R3 release lever [B] and pull out the stapler unit.
3. Remove the harness cover [C].
4. Remove the stapler unit [D] (1 connector and 1 screw).

**NOTE:** When re-assembling the parts, hook the cutout [E] to the shoulder screw [F].

### 3.3 JOGGER PLATE REMOVAL AND INSTALLATION

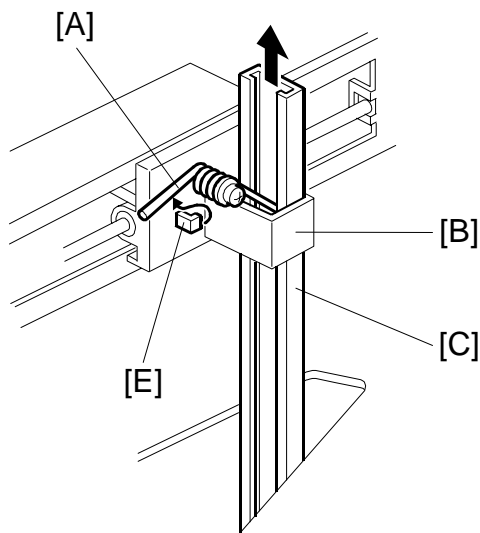

A831R503.WMF

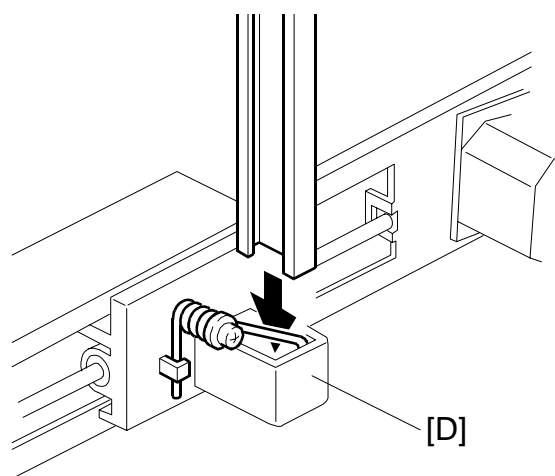

A831R504.WMF

#### **Removal**

1. Remove the proof tray. (Refer to Exterior Cover Removal, section 4.1.)
2. Release the spring [A] of the upper jogger holder [B], and then pull out the jogger plate [C].

#### **Installation**

1. Insert the jogger plate through the upper holder [B].
2. Push down the jogger plate towards the lower holder [D].
3. Set the jogger plate in the lower holder [D].
4. Hook the spring [A] of the upper jogger holder to the stopper [E].

## 3.4 BINS REMOVAL

### Removal

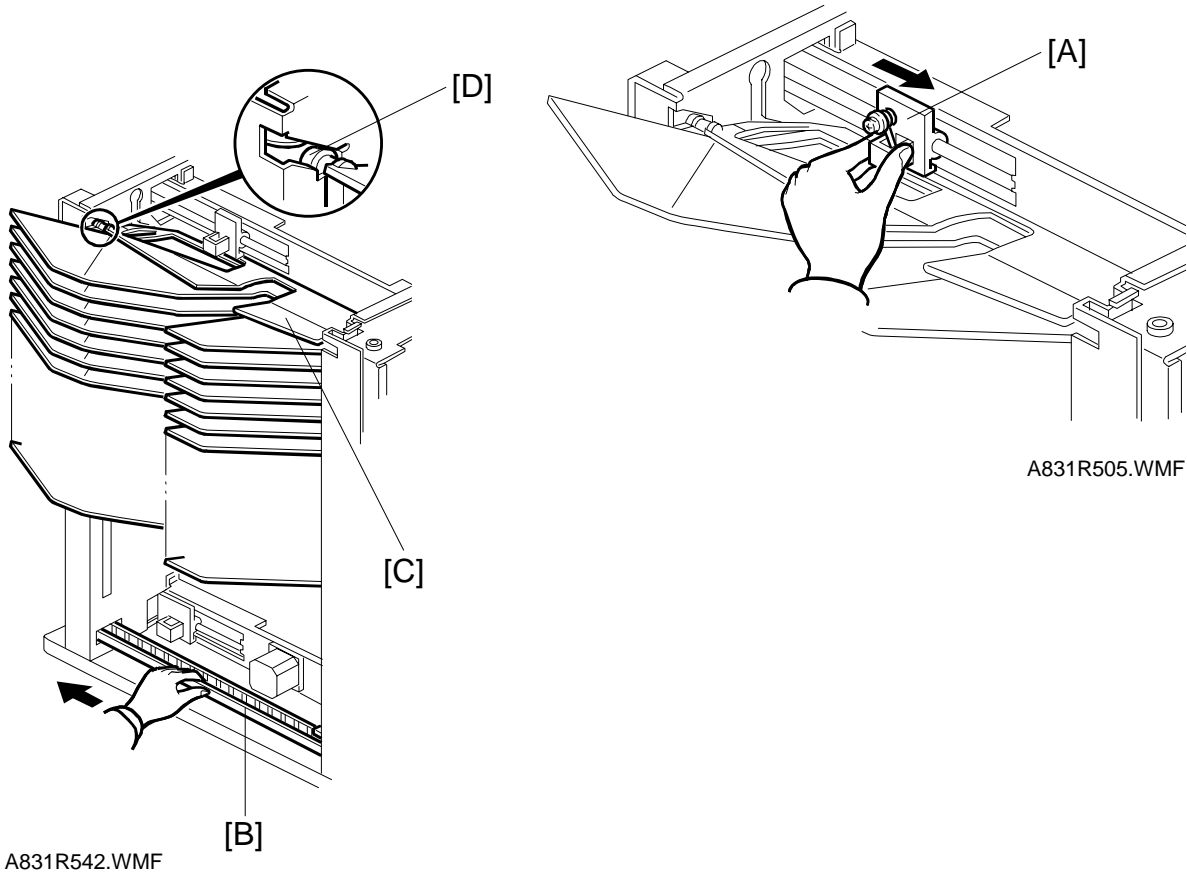

1. Remove the rear cover.
2. Raise all bins to the highest position by turning on DIP SW100-1 on the main PCB for the sorter, then turn off the main switch of the copier.
3. Remove the jogger plate (refer to Jogger Plate Removal) then move the upper jogger holder [A] to the front side.
4. Remove the rear cover then remove the bottom plate to access the drive belt. (Refer to Exterior Cover Removal section.)
5. Manually rotate the helical wheel drive belt [B] and move up the top guide [C] until the three guide pins [D] reach the top of the helical wheel as shown.

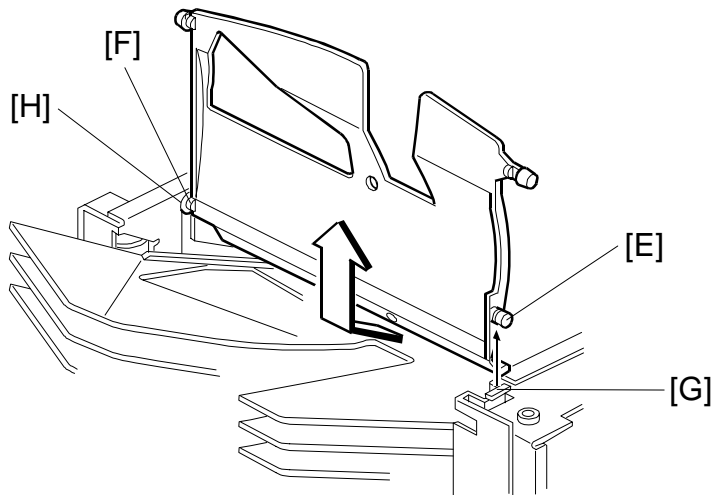
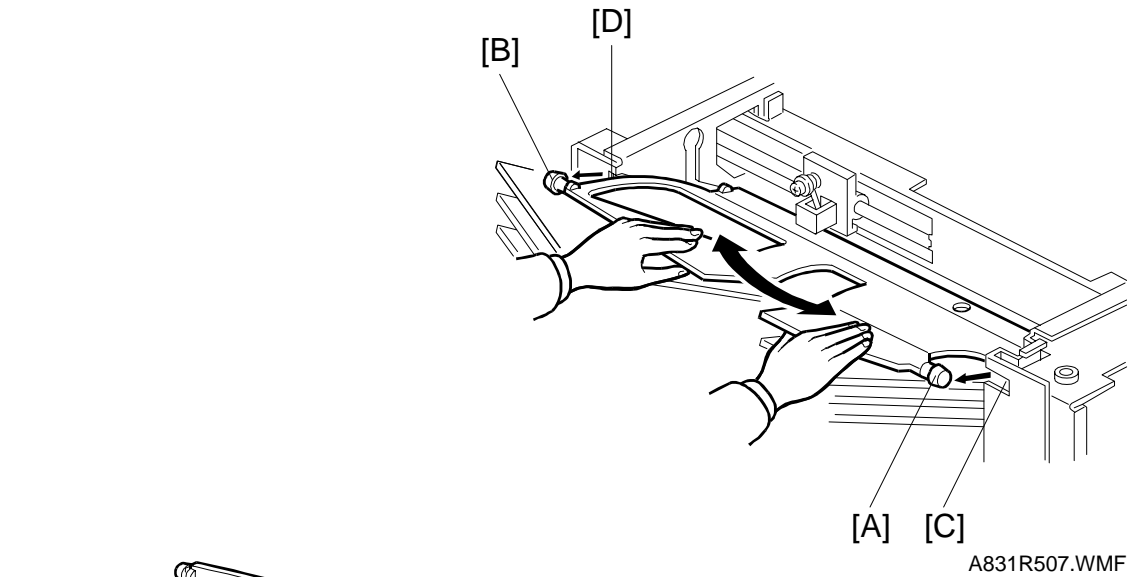

6. Remove the top guide by releasing two pins [A and B] from the cutouts [C and D] at the end of the bin guide slots. Then remove the pins [E and F] from the cutouts [G and H].
7. Move the next bin to the top position by manually rotating the helical wheel drive belt and remove it according to the removal procedure for the top guide (step 5 and 6).
8. Remove the other nineteen bins by repeating step 7.

Peripherals

**Installation**

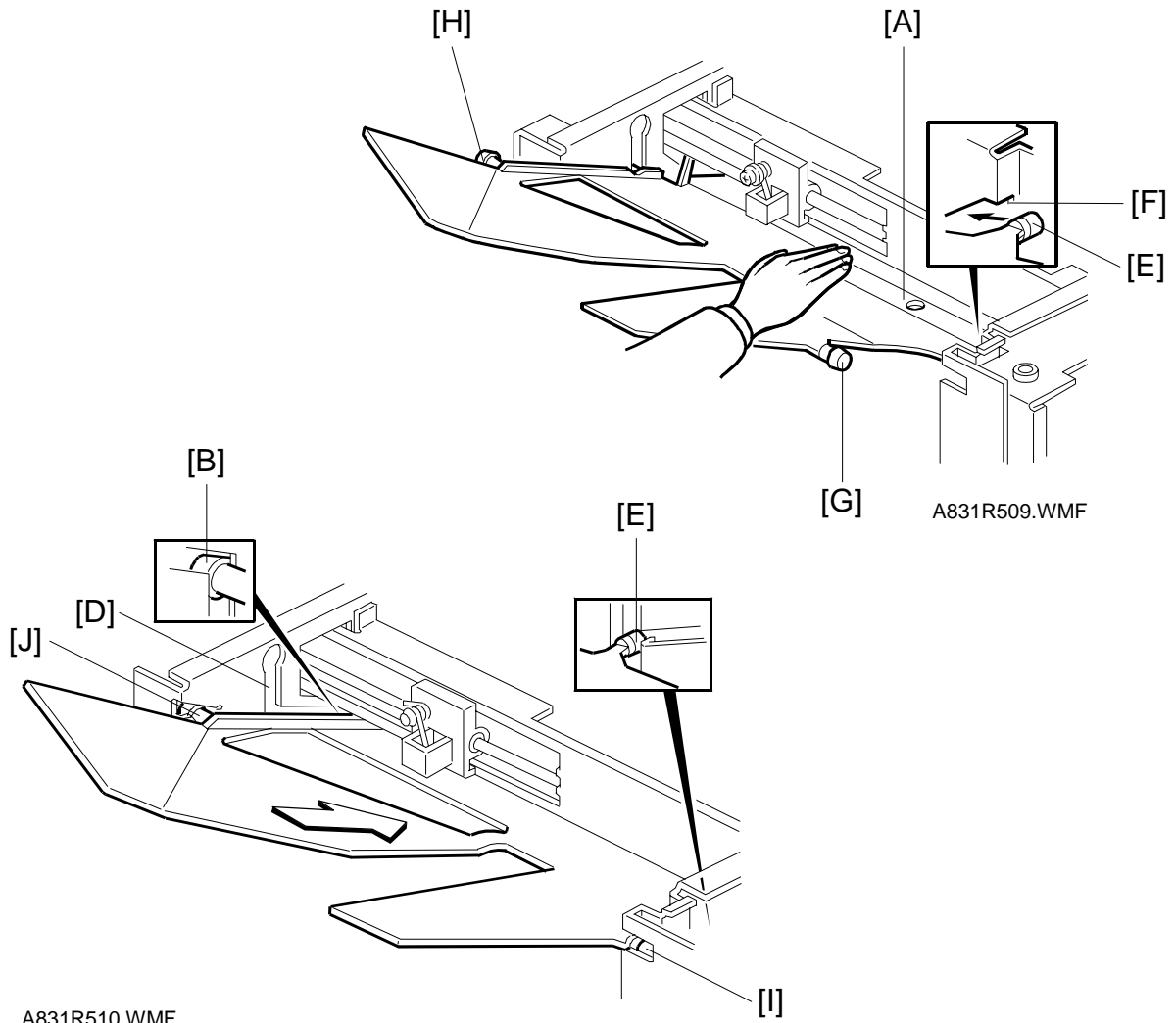

1. While holding the bin rear plate [A] straight, insert the rear right guide pin [B] into the slot [C], and then lower the rear guide pin to the corner [D].
2. While still holding the bin rear plate straight, insert the front right guide pin [E] to guide slot [F].
3. Insert the other guide pins [G] and [H] to the slots [I] and [J].

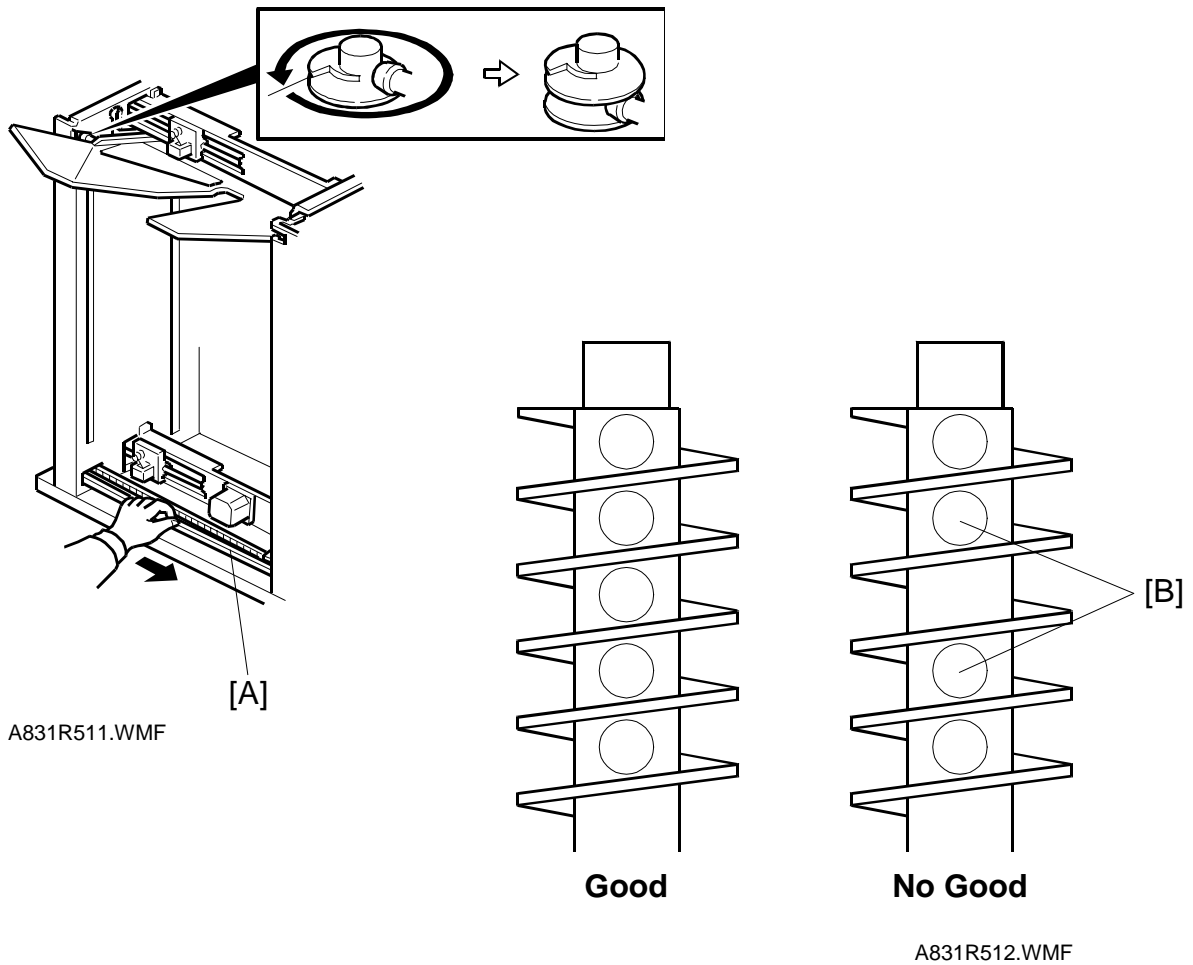

4. Manually rotate the helical wheel drive belt [A] and lower the bin.  
**NOTE:** Before installing the next bin, rotate the helical wheels only once. Otherwise, the distance between the guide pins [B] become uneven and the bin tilts.
5. Set all bins and the top cover by repeating steps 1 to 4.
6. Re-install the jogger plate and all covers.

Peripherals

### 3.5 MAIN MOTOR REMOVAL

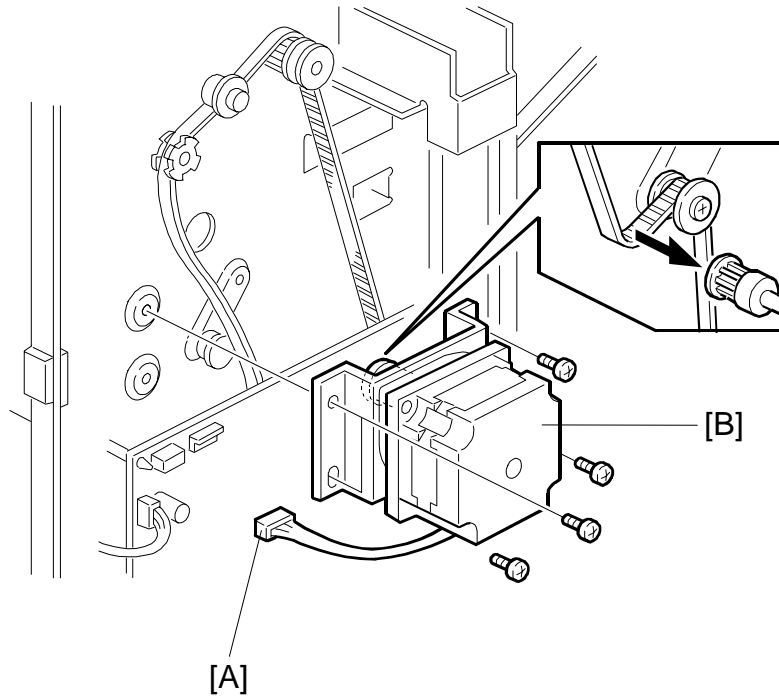

A831R116.WMF

1. Remove the rear cover (4 screws).
2. Disconnect the connector [A].
3. Remove the main motor [B] (4 screws).

### 3.6 GRIP ASSEMBLY REMOVAL

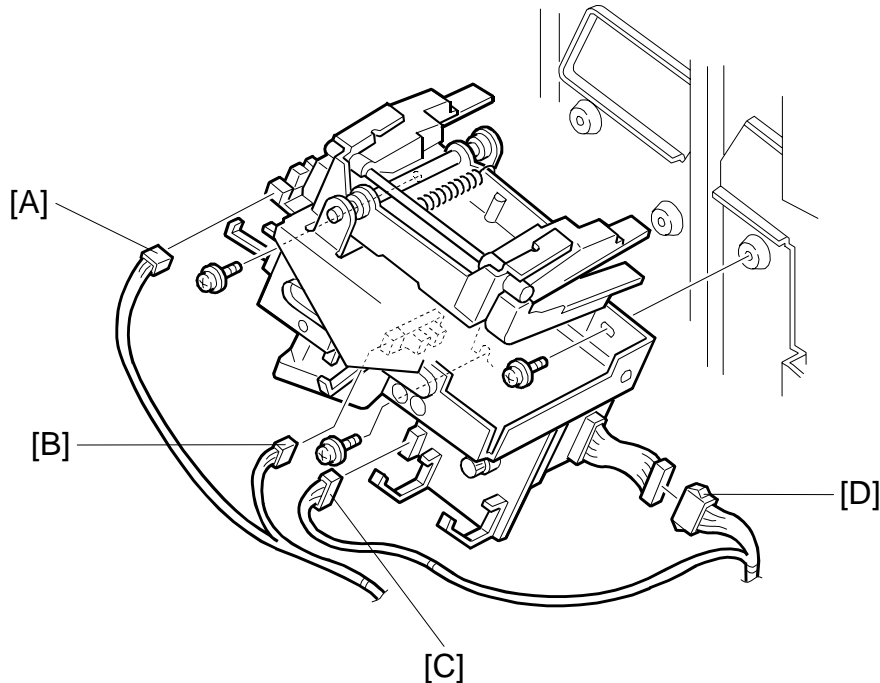

A831R514.WMF

1. Open the front door then remove the front inner cover. (Refer to Exterior Cover Removal, section 4.1.)
2. Disconnect the four connectors [A to D].  
**NOTE:** When re-connecting the connectors, connect the longer harness [A] to grip shift motor HP sensor and the shorter harness [B] to grip motor HP sensor.
3. Remove the grip assembly.



### 3.7 UPPER GRIP ASSEMBLY REMOVAL

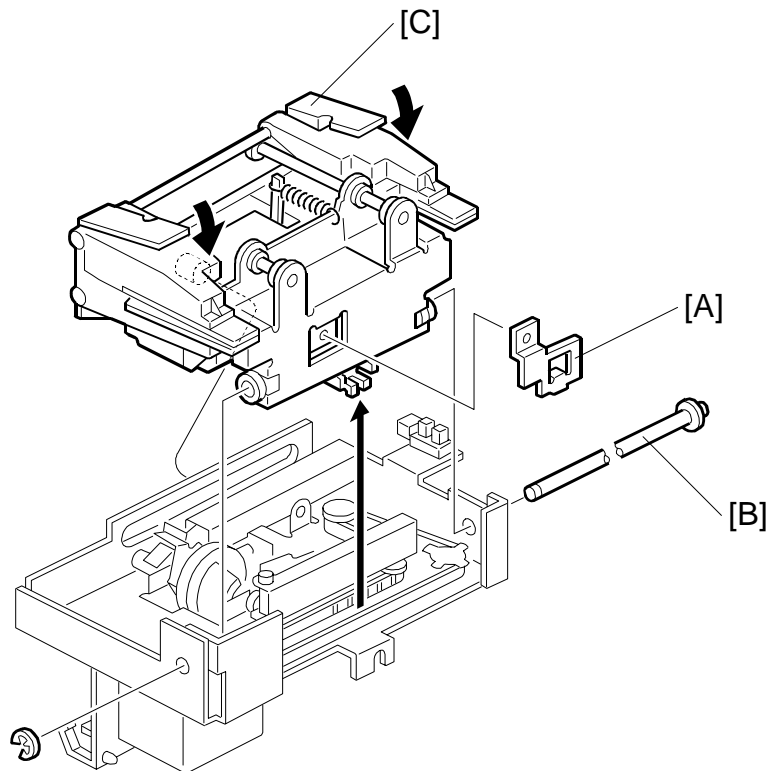

A831R515.WMF

1. Remove the grip assembly. (Refer to Grip Assembly Removal, section 4.6.)
2. Remove the timing belt securing bracket [A] (1 screw).
3. Remove the grip shift shaft [B] (1 E-ring).
4. While closing the upper-grip assembly [C], remove it.

### 3.8 GRIP SHIFT MOTOR REMOVAL

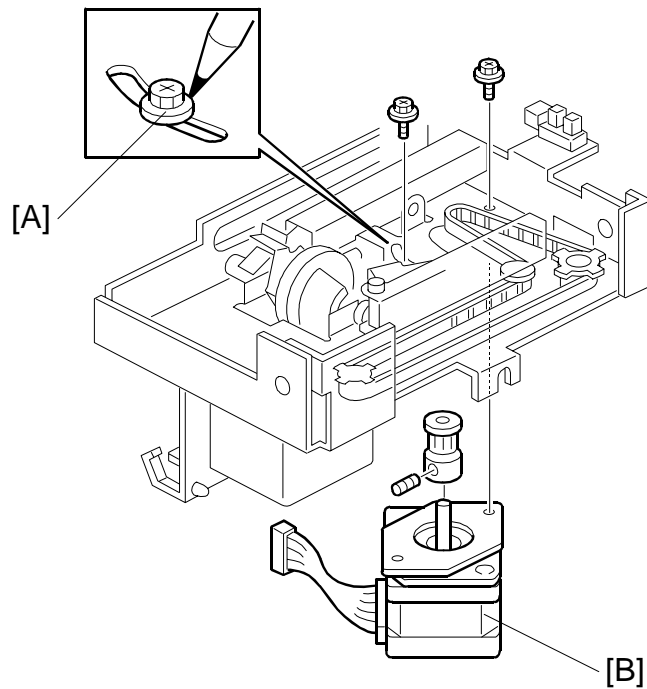

A831R516.WMF

1. Remove the upper grip assembly. (Refer to Upper Grip Assembly Removal, section 4.7.)
2. Mark the original position of the screw [A] securing the grip shift motor [B].
3. Remove the grip shift motor.  
**NOTE:** When re-installing the grip shift motor, place the motor at the original position by referring to the mark you made.

### 3.9 HELICAL WHEELS REMOVAL

#### Removal

Before removing the helical wheels, remove all bins and all exterior covers. (Refer to Exterior Cover, section 4.1, and Bins Removal, section 4.4.)

#### Front Helical Wheel

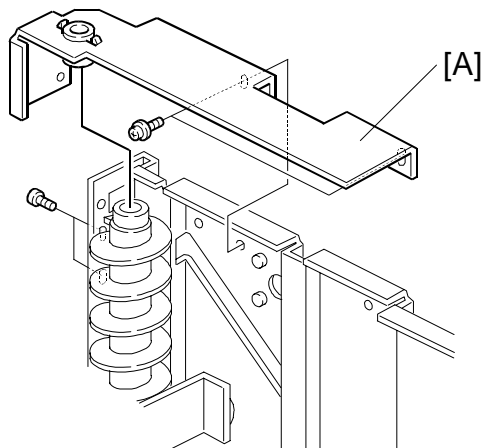

A831R523.WMF

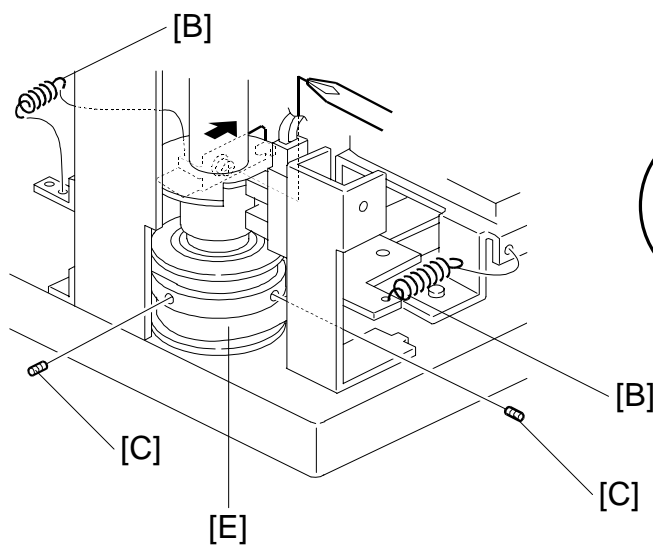

A831R525.WMF

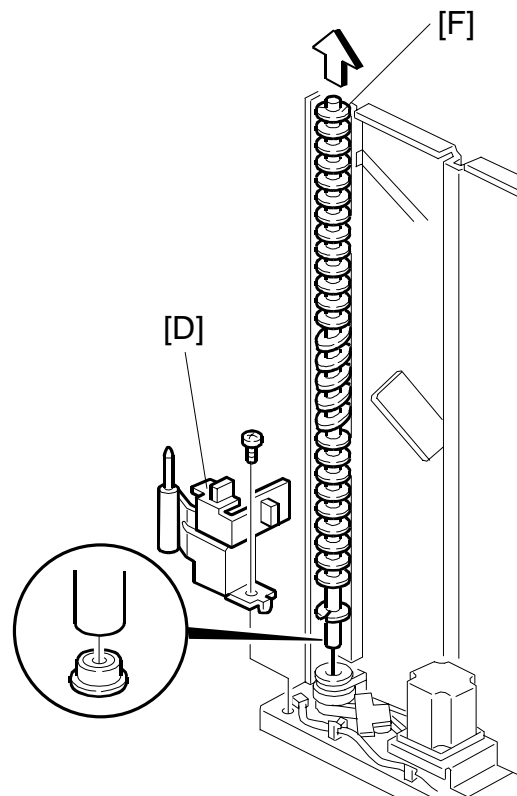

A831R524.WMF

1. Remove the bracket [A] (4 screws).
2. Unhook the two springs [B].
3. Loosen the two Allen screws [C].
4. Remove the wheel sensor bracket [D] (1 screw).
5. While holding the pulley [E] to keep it in position, remove the helical wheel [F].

**Rear Helical Wheel**

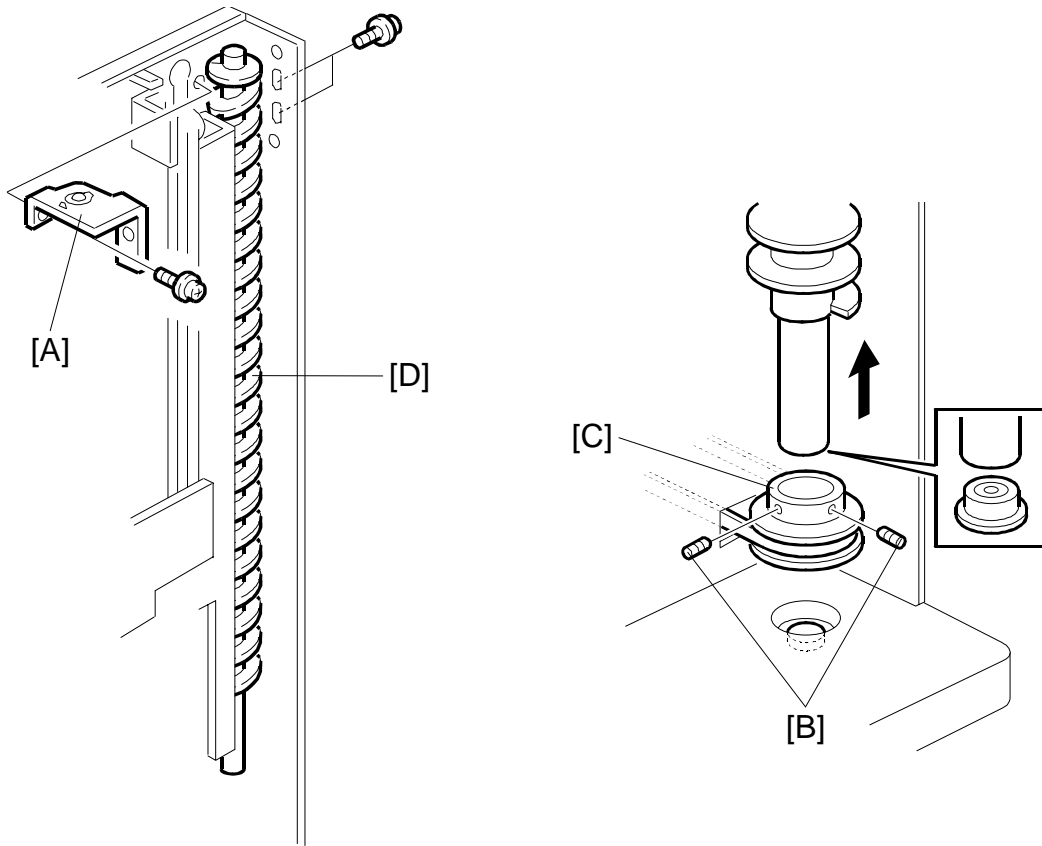

A831R526.WMF

A831R527.WMF

1. Remove the bracket [A] (3 screws).
2. Loosen the two Allen screws [B] on the drive pulley.
3. While holding the pulley [C] to keep it in position, remove the helical wheel [D].

**Installation**

**NOTE:** After installing the helical wheels, perform the helical wheels alignment which is explained later.

**Rear Helical Wheel**

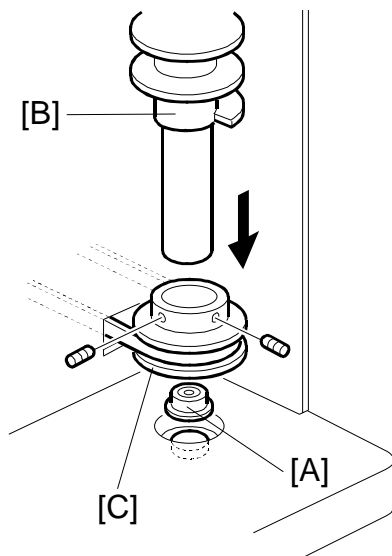

A831R528.WMF

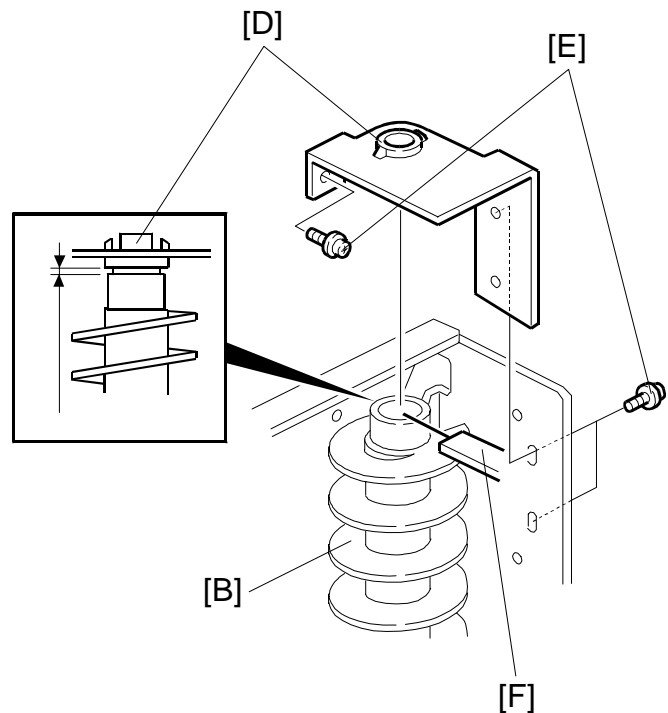

A831R529.WMF

1. Place the bearing [A] on the notch on the bottom plate.
2. Set the helical wheel [B] into the pulley [C] then set the helical wheel on the bearing [A].
3. Set the bracket with the bushing [D] on top of the helical wheel then install and slightly tighten three screws [E].
4. Place a 0.4-mm thickness gauge [F] between the helical wheel [B] and the bushing [D] on the bracket. While holding the bushing down to the helical wheel, tighten the three screws [E].

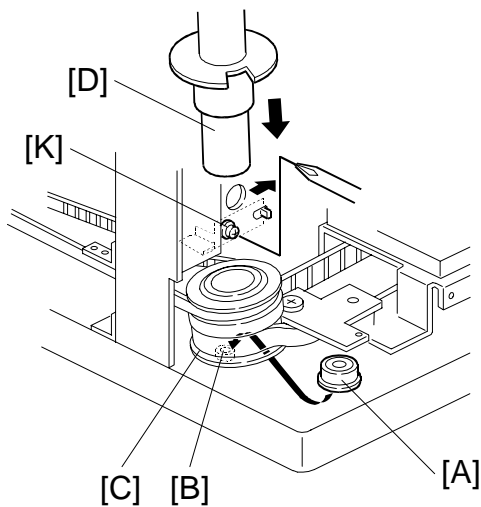
**Front Helical Wheel**

A831R530.WMF

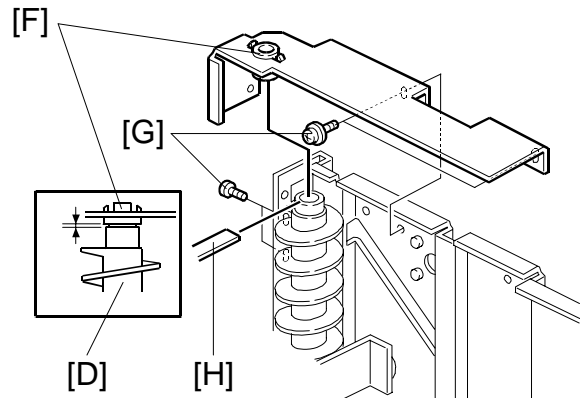

A831R531.WMF

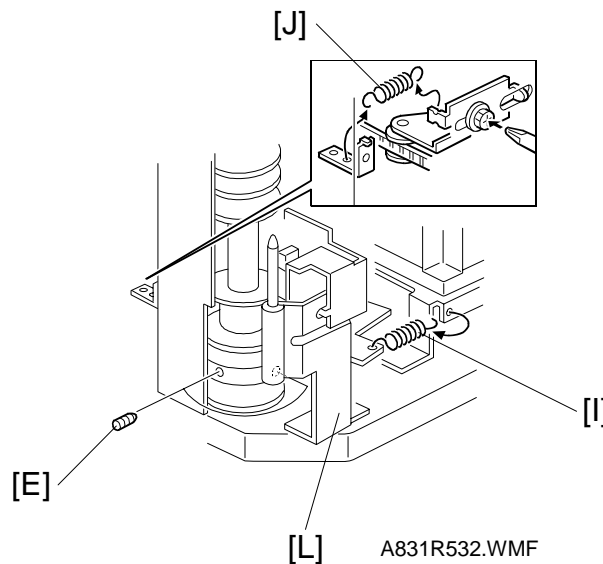

A831R532.WMF

1. Place the bearing [A] on the notch [B] on the bottom plate.
2. Set the pulley [C] on the bearing. The direction of the pulley should be as shown in the illustration.
3. Set the helical wheel [D] in the pulley [C]. Leave the Allen screws [E] loosened.
4. Set the bracket with a bushing [F] on top of the helical wheels then install and slightly tighten the four screws [G].
5. Place a 0.4-mm thickness gauge [H] between the helical wheel and the bushing on the bracket. While holding the bushing down to the helical wheel [D], tighten the four screws [G].
6. Hook tension springs [I and J] then tighten the screw [K].
7. Install the wheel sensor bracket [L].

**Alignment of the 2 Helical Wheels**

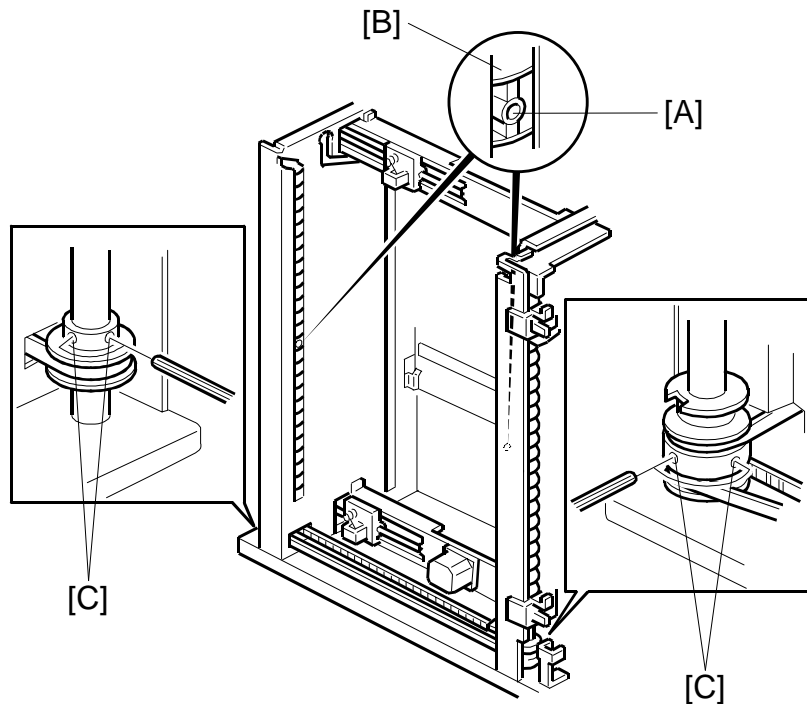

A831R533.WMF

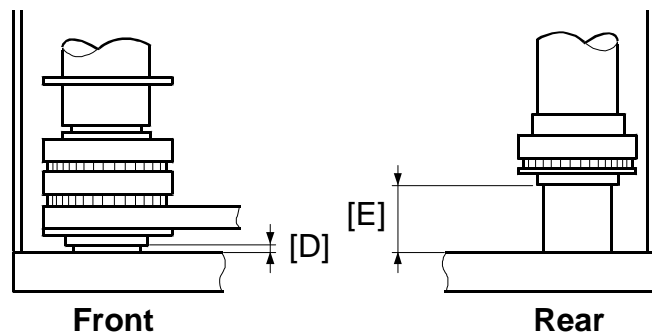

D =  $1.7 \pm 0.5$  mm  
 E =  $22.5 \pm 0.5$  mm

A831R534.WMF

1. Confirm all belts are set correctly.
2. Align all holes [A] at the middle of the helical wheels at the center of the bin guide slots [B], as shown.
3. In this condition, tighten all Allen screws [C] on the helical wheel drive pulleys (2 Allen screws on each drive pulley).

Make sure that the gaps [D and E] between the base plates and the pulleys are as shown in the illustration.

## 3.10 GRIP MOTOR AND SENSORS REMOVAL

### 3.10.1 GRIP MOTOR/GRIP MOTOR HP SENSOR/GRIP SHIFT MOTOR HP SENSOR REMOVAL

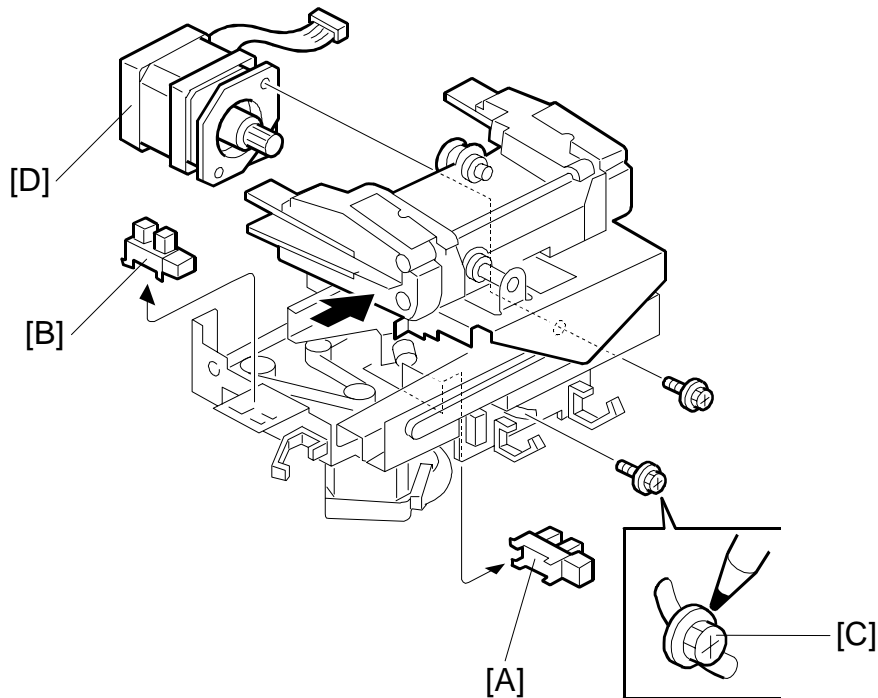

A831R517.WMF

1. Remove the grip assembly. (Refer to Grip Assembly Removal, section 4.6.)
2. Replace the grip motor HP sensor [A].
3. Replace the grip shift motor HP Sensor [B].
4. Mark the original position of the screw [C] securing the grip motor [D].
5. Remove the grip motor.

**NOTE:** When re-installing the grip motor, place the motor at the original position by referring to the mark you made.



### 3.11 MAIN CONTROL BOARD REPLACEMENT

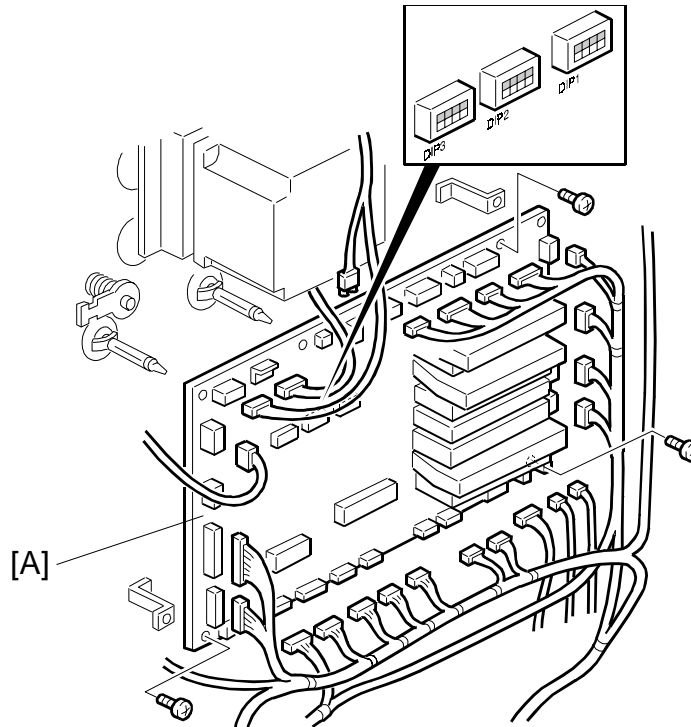

A831R518.WMF

1. Remove the rear cover (refer to Exterior Cover Removal, section 4.1) then disconnect all connectors.
2. Remove the main control board [A] (3 screws).
3. Install the new main control board and set all connectors.
4. Position DIP 1, 2 and 3 as on the original main control board (DIP 1 is for SP mode, DIP 2 and 3 are for staple position adjustment).
5. Turn on the main switch for the copier, and then confirm the staple position. If incorrect, adjust the staple position. (Refer to the SP mode Staple Position Adjustment, section 4.11.)

## 4. SP MODE AND STAPLE POSITION ADJUSTMENT

### 4.1 SERVICE TABLES (MAIN CONTROL BOARD)

#### 4.1.1 DIP SWITCHES

##### *DIP 1 (Mode) SP Mode*

1	2	3	4	Function
0	0	0	0	Normal Setting
0	1	0	0	System Free Run 1
1	0	0	0	Durability Free Run
1	1	0	0	System Free Run 2
1	1	1	0	Bin Top Position
—	—	—	1	PCB Test

0: OFF 1: ON —: Not Concerned

##### *DIP 2 (Staple) Staple Position Adjustment (A)*

##### *DIP 3 (Chuck) Staple Position Adjustment (B)*

1	2	3	4	Standard Position
0	0	0	—	± 0 mm
1	0	0	0	+ 0.5 mm
0	1	0	0	+ 1.0 mm
1	1	0	0	+ 1.5 mm
0	0	1	0	+ 2.0 mm
1	0	1	0	+ 2.5 mm
0	1	1	0	+ 3.0 mm
1	1	1	0	+ 3.5 mm
1	0	0	1	- 0.5 mm
0	1	0	1	- 1.0 mm
1	1	0	1	- 1.5 mm
0	0	1	1	- 2.0 mm
1	0	1	1	- 2.5 mm
0	1	1	1	- 3.0 mm
1	1	1	1	- 3.5 mm

0: OFF 1: ON —: Not Concerned

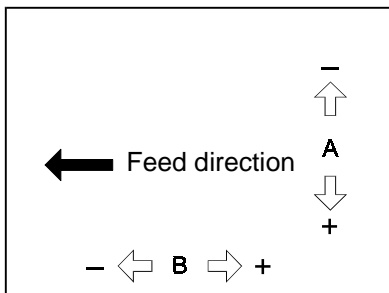

A831M051.WMF

# 20 BIN SORTER STAPLER (A831) POINT TO POINT DIAGRAM

